

Cathodic Protection Catalog

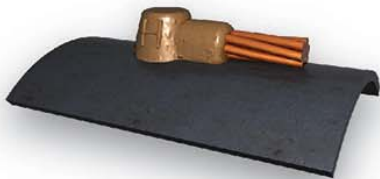
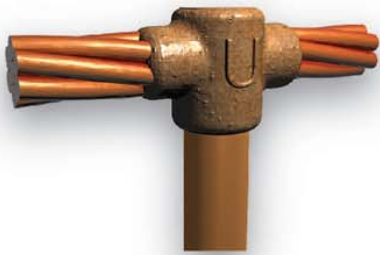

Harger Lightning & Grounding

Cathodic Protection Equipment Catalog

Since its beginning in 1960, Harger Lightning & Grounding has become a leader in the grounding, lightning protection, rail and cathodic protection industries. Founded on the principles of honesty, integrity and technical expertise, Harger has been able to provide Cathodic protection equipment for many satisfied customers.

Harger Lightning & Grounding has built its reputation on providing a broad line of quality products at a competitive price, coupled with extraordinary service.

We have experience in all facets of these markets including product manufacturing and installation. We have the staff and facilities to handle your special requirements. Our complete engineering and manufacturing facilities have the capacity to produce special items as well as modify our standard component line. Let us know the application and we can provide the necessary equipment.

In order to meet the rigorous demands of our markets, Harger maintains an extensive inventory to ensure prompt deliveries to our customers, domestically and worldwide. Headquartered near Chicago, Illinois, Harger is centrally located to serve the needs of customers from coast to coast.

**Information changes after the catalog is printed.
For the most up to date information,
please go to our website at
www.harger.com**

Table of Contents

Introduction	
Exothermic Process	4
NUWTube Welding Process.....	5
Mold Reference	
Mold Numbering System	6
Conductor Identification	7
Steel Pipe Sizes.....	8
Ground Rods	8
Connection Types	9
Molds	
Cathodic Kit	10
CAHD	10
CAHT.....	11
CAVA.....	12
CAVDO.....	13
CACIHD	14
CACIHT.....	14
CACIVA.....	15
CACIVDO	15
CART.....	16
CABS.....	17
CAPB.....	17
CAPS.....	18
CAPT	18
CAGD	19
CAGO	19
NUWTube Uni-Shots.....	20
CALE	21
Hammer Dies	22
CAHDFB.....	22
CACIHDFB	22
Copper Jumper Bonds	23
Copper Strap Bonds.....	23
Materials, Tools & Accessories	
Molds.....	24
Adapting Molds to Fit Conductors	25
Adapter Sleeves	25
Wrap Sleeves	25
Mold Accessories	25
Torch Head	25
Mold Care & Use	26
Mold Sealer.....	26
Disks	26
Flint Igniter.....	26
Cable & Work Surface Preparation	26
Cold Galvanizing Spray.....	26
Rasp.....	26
Mold Fastening & Mounting	27
Magnetic Hold Down For A Molds	27
Chain Support Kit - Horizontal Pipe	27

Chain Support Kit - Vertical Pipe	27
Chain Support Kit - Horizontal Pipe	27
Chain Support Kit - Vertical Pipe	27
Mold Handle Clamp	27
Grounding Components	
Solid Tinned Copper Conductor	28
Solid Single Soft-Drawn Bare Tinned Copper	28
Solid Single Soft-Drawn Bare Copper	28
Solid Copper Conductor	28
Stranded Copper Conductor	29
Green Insulated Conductor	29
Concentric Lay Soft-Drawn Bare Copper	29
Galvanized Steel Ground Rod	30
Copper Clad Steel Ground Rod	30
Ground Rod Driver	30
Ultrafill - Earth (Ground) Enhancement Material	31
Ground Access Wells	32
Light Weight Polymer Concrete	32
PVC Slotted Well with Cover	33
PVC Well with Cover	33
HDPE Well with Cover	33
UL Listed Prefabricated Copper Ground Mesh	34
Personnel Safety Mats	35
Two Hole Long Barrel Compression Lugs	36
One Hole Compression Lugs	36
Universal Ground Rod Clamp - Light Duty	37
Copper Offset Terminal Lugs	37
Copper Split Bolts	37
Ground Rod Clamps	37
C-Type Compression Taps	38
Mechanical Compression Tools	38
Heavy Duty C-Taps	38
Megger Ground Testing Equipment	39
High Sensitivity Ground Resistance Tester	39
4 Terminal Ground Resistance Testers	39
Megger Earth/Ground Resistance & Leakage Current Clamp Testers	39
Harger Ground Test Kits	40

Exothermic Process

The Exothermic Process is an effective and safe method of welding copper to copper, copper to cast iron or copper to steel for the purpose of producing permanent electrical connections. Exothermically welded connections are produced from the energy and molten copper metal liberated from an exothermic reaction between powdered copper oxide and aluminum. The exothermic reaction takes place at a theoretical temperature of 4600°F and as a result, molten copper alloy is created and used to melt the conductors and cast the finished connection. The exothermic reaction takes place in a semi-permanent graphite mold that will last 50 or more welds if properly cared for. The process is simple and easy to implement providing an on-site means to make welded electrical connections without requiring external power, equipment or the special training usually required for brazing and welding. The process will provide a finished connection that will always provide an ampacity that exceeds the conductors they join and will never loosen.



NUWTube Welding Process

Step 1:

Read all instructions and safety precautions included with each mold and follow recommendations for safe use. Pay attention to the placement of the conductors in the weld cavity as this will affect the quality of the finished weld.

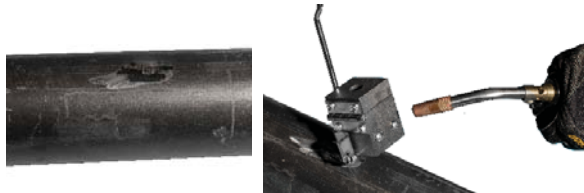
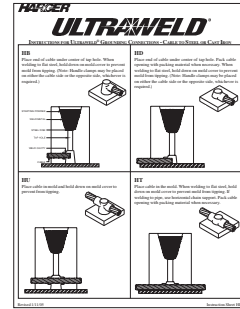

Step 2:

Prepare Mold and Conductors by preheating mold and cleaning and drying conductors. All conductors should be free of dirt, oil, and oxidation. When welding to steel, be sure to clean the steel down to bright steel.

Step 3:

Position mold on surface to be welded with conductors in proper position in mold per instruction sheet. A support clamp can be used to help hold the mold in place.



Step 4:

Place disc in mold making sure it properly seals the tap of the mold.



Step 5:

Remove clear cap on tube and pour weld metal into crucible. Be sure that you don't displace disc in bottom of crucible.



Step 6:

Close lid. Remove orange cap on tube and pour starting material on the edge of the ignition hole. Use flint igniter to ignite material.

Step 7:

Remove mold and inspect weld. Be sure to clean mold for next application.



Mold Numbering System

The Part Number gives, in code, the complete information of the mold.

- Type of connection, conductor size(s) and mold price key.
- If frame or handle clamp is not required, add a suffix "X" after the mold part number.
- See charts on pages 7 & 8 for code references.
- The below number are examples only. For actual part numbers, please refer to the proper pages in this catalog or request a number from Harger customer service.
- If there is a "H" or a "V" after the primary conductor then the secondary conductor is a pipe in a horizontal or vertical orientation, respectively.

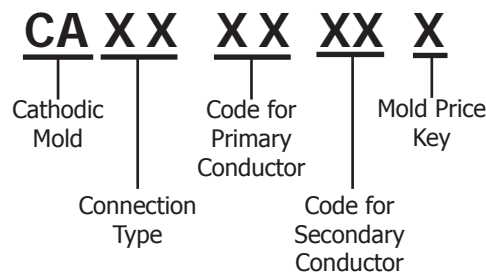

Example: CAHD4SH4X5A
 #4 Solid to a 4" to 5" Horizontal pipe

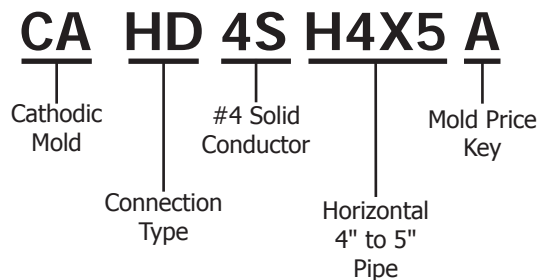

Example: CAVA6V.75X3.5L
 #6 Stranded to a 3/4" to 3-1/2" Vertical pipe

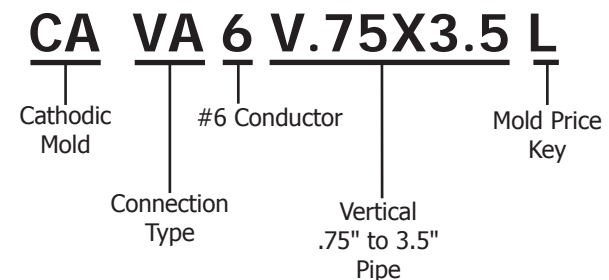

Conductor Identification

Bare Class A, B, and C Concentric Stranded Conductors Based on A.S.T.M Standard Specifications

Size in Circular mils	Size A.W.G.	Conductor Diameter	Number of Wires					Cable Code
			7	19	37	61	91	
1,000,000	1000	1.152"			.1644*	.1280	0.148	1MM
800,000	800	1.031"		.1470*	.1145	.0938		8CM
750,000	750	.998"		.1424*	.1109	.0908		75CM
700,000	700	.964"		.1375*	.1071	.0877		7CM
600,000	600	.893"		.1273	.0992	.0812		6CM
500,000	500	.813"		.1622*	.1162	.0905		5CM
400,000	400	.728"		.1451	.1040	.0810		4CM
350,000	350	.681"		.1357	.0973	.0757		35CM
300,000	300	.630"		.1257	.0900	.0701		3CM
250,000	250	.575"		.1147	.0822	.0640		25CM
211,600	4/0	.528"	.1739	.1055	.0756			4/0
167,800	3/0	.470"	.1548	.0940	.0763			3/0
133,100	2/0	.419"	.1379	.0837	.0600			2/0
105,500	1/0	.373"	.1228	.0745	.0534			1/0
83,690	1	.332"	.1093	.0664	.0467			1
66,370	2	.292"	.0974	.0591				2
52,630	3	.260"	.0867	.0526				3
41,740	4	.232"	.0772	.0469				4
26,240	6	.184"	.0612	.0372				6
16,510	8	.146"	.0486	.0295				8
10,380	10	.116"	.0385	.0234				10
6,530	12	.0915"	.0305	.0185				12
4,110	14	.0726"	.0242	.0417				14

* Class AA

Bare Solid Copper Conductors Based on A.S.T.M Standard Specifications

Size A.W.G.	Cross Sectional Area Circular Mils	Wire Diameter	Cable Code
4/0	211,600	.4600"	4/0S
3/0	167,800	.4096"	3/0S
2/0	133,100	.3648"	2/0S
1/0	105,500	.3249"	1/0S
1	83,690	.2893"	1S
2	66,370	.2576"	2S
3	52,630	.2294"	3S
4	41,740	.2043"	4S
6	26,250	.1620"	6S
8	16,510	.1285"	8S
10	10,380	.1019"	10S
12	6,530	.0808"	12S
14	4,110	.0641"	14S

Conductor Area Conversions

Square Inches x 1273 = MCM

MCM x 7.862×10^{-4} = Square Inches

Square Inches x 645.2 = Square Millimeter

Square Millimeter x 1.550×10^{-3} = Square Inches

Square Millimeters x 1.9736 = MCM

MCM x 0.5067 = Square Millimeters

1 MCM = 1 kcmil = 1,000 circular mil

Steel Pipe Sizes

Standard Weight (Schedule 40) ASTM A53-90-B
ANSI/ASME B36.10M-1985

Nominal Size	O.D.	Wall Thickness	Mold Code
1"	1.315"	.133"	1
1-1/4"	1.66"	.14"	1.25
1-1/2"	1.9"	.145"	1.5
2"	2.375"	.154"	2
2-1/2"	2.875"	.203"	2.5
3"	3.5"	.216"	3
3-1/2"	4"	.226"	3.5
4"	4.5"	.237"	4
5"	5.563"	.258"	5
6"	6.625"	.28"	6
8"	8.625"	.322"	8
10"	10.75"	.365"	10







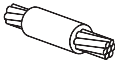
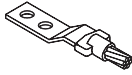

Ground Rods

Nominal Size	Material	Type	Body Diameter	Thread Size	Ground Rod Code
1/2"	Copper-clad	Sectional	.505"	9/16"	12F
	Copper-clad	Plain	.50"	N/A	12F
	Steel*	Plain	.50"	N/A	12F
	Copper-clad	Plain	.475"	N/A	12
5/8"	Steel*	Plain	.625"	N/A	58F
	Copper-clad	Plain	.563"	N/A	58
	Copper-clad	Sectional	.563"	5/8"	58S**
3/4"	Steel*	Plain	.75"	N/A	34F
	Copper-clad	Plain	.682"	N/A	34
	Copper-clad	Sectional	.682"	3/4"	34S**
1"	Steel*	Plain	1.00"	N/A	10F
	Copper-clad	Plain	.914"	N/A	10
	Copper-clad	Sectional	.914"	1"	10S**

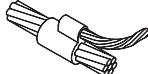
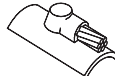
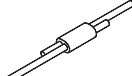
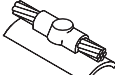
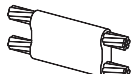
* Plain steel, stainless steel, stainless clad rods or galvanized steel.

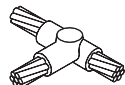
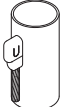
** Add S to sectional ground rod size for connections to end of rod such as:
GD, GF, GO, GT, GG

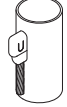
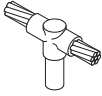
Connection Types

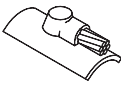
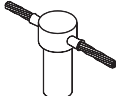
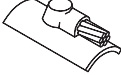
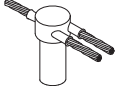
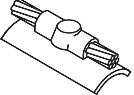
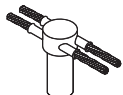
Connection Type	Page	Connection Type	Page
 CABS	17	 CALE	21
 CACIHD.....	14	 CAPB.....	17
 CACIHDFB.....	22	 CAPS	18
 CACIHT	14	 CAPT	18
 CACIVA	15	 CART	16
 CACIVDO	15	 CAVA.....	12
 CAGD	19	 CAVDO	13
 CAGO	19	 G11	20
 CAHD	10	 G21	20
 CAHDFB	22	 G31	20
 CAHT.....	11	 G41	20

Mold Reference

Mold Information:

- CAHD mold - cable is **on** the steel surface.
- Price Key "A" Molds include Frame and Flint Igniter.
- Price Key is the **Bold Letter** in the Mold Part No.

Recommended Tools & Accessories:

- RASP - Metal Rasp
- CCBRSH1 - Card Cloth Brush
- MCBRSH1 - Large Mold Cleaning Brush
- MCBRSH2 - Small Mold Cleaning Brush
- MLDSLR - Mold Sealer (1/0 and Larger)
- CMCSPD - Cleaning Spade
- UMMHDA - Hold Down Kit when Price Key is "A"
- CSKITHPA - Chain Support Kit - Horizontal Pipe

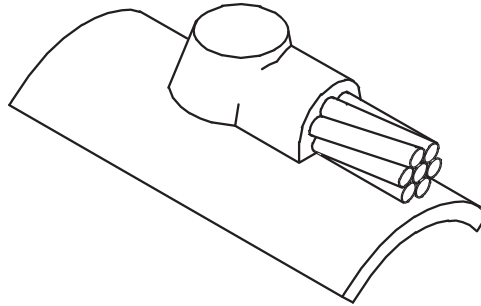

CAHD
(Cathodic Horizontal Butt
DOWN on Surface)

NOTES:

- For CAHD molds, a mold sealer may be required when welding conductors 1/0 and larger.

Cathodic Kit



Kit for connecting to Pipe 3/4" and Larger	
Part No. for Kit:	CPKIT
Included parts:	
Mold for 3/4" to 3.5"	1 Ea. CAHD6S.75x3.5A
Mold for 4" and Larger (Flat)	1 Ea. CAHD6SA
Adapter Sleeves	100 Ea. ADPSLV6
Shots	100 Ea. NUWTUBE15CA
Cleaning Spade	1 Ea. CMCSPD
Flint Gun	1 Ea. FLTIG
Handy Carrying Case	1 Ea. TOOLBOX2

CAHD Connection Type

Conductor Size	Surface	Part No.	Weld Metal	
#14 to #10 Solid (use sleeve ADPSLV6)* or #8 Solid or Stranded or #6 Solid	Flat (4" & larger pipe)	CAHD6SA	NUWTUBE15CA	
	3/4" to 3-1/2" pipe	CAHD6SH.75X3.5A		
6 Stranded	Flat (4" & larger pipe)	CAHD6A		
	3/4" to 3-1/2" pipe	CAHD6H.75X3.5A		
4 Solid	Flat (6" & larger pipe)	CAHD4SA		
	3/4" to 3-1/2" pipe	CAHD4SH.75X3.5A		
	4" to 5" pipe	CAHD4SH4X5A		
4 Stranded	Flat (6" & larger pipe)	CAHD4A		
	3/4" to 3-1/2" pipe	CAHD4H.75X3.5A		
	4" to 5" pipe	CAHD4H4X5A		
2 Solid	Flat (10" & larger pipe)	CAHD2SA		NUWTUBE25CA
	1" to 3-1/2" pipe	CAHD2SH1X3.5A		
	4" to 8" pipe	CAHD2SH4X8A		
2 Stranded	Flat (16" & larger pipe)	CAHD2A	NUWTUBE32CA	
	1" to 3-1/2" pipe	CAHD2H1X3.5A		
	4" to 8" pipe	CAHD2H4X8A		
	10" to 14" pipe	CAHD2H10X14A		
1 Stranded	Flat (16" & larger pipe)	CAHD1A	NUWTUBE45CA	
	4" to 8" pipe	CAHD1H4X8A		
	10" to 14" pipe	CAHD1H10X14A		
1/0 Stranded	Flat (20" & larger pipe)	CAHD1/0A	NUWTUBE65CA	
	2-1/2" to 3-1/2" pipe	CAHD1/0H2.5X3.5A		
	4" to 8" pipe	CAHD1/0H4X8A		
	10" to 18" pipe	CAHD1/0H10X18A		
2/0 Stranded	Flat (20" & larger pipe)	CAHD2/0A	NUWTUBE65CA	
	2-1/2" to 3-1/2" pipe	CAHD2/0H2.5X3.5A		
	4" to 8" pipe	CAHD2/0H4X8A		
	10" to 18" pipe	CAHD2/0H10X18A		

Molds

Mold Information:

- CAHT mold - cable is on the steel surface.
- Price Key "A" Molds include Frame and Flint Igniter.
- Price Key is the **Bold Letter** in the Mold Part No.

Recommended Tools & Accessories:

- RASP - Metal Rasp
- CCBRSH1 - Card Cloth Brush
- MCBRSH1 - Large Mold Cleaning Brush
- MCBRSH2 - Small Mold Cleaning Brush
- MLDSLRL - Mold Sealer (1/0 and Larger)
- CMCSPD - Cleaning Spade
- CSKITHPA - Chain Support Kit - Horizontal Pipe

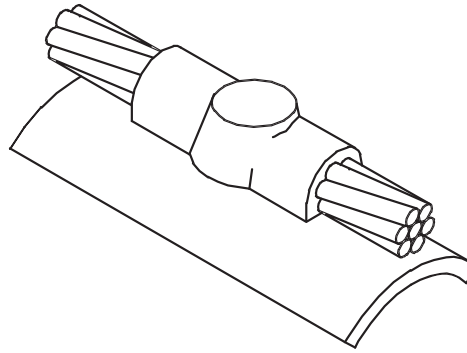

CAHT

(Cathodic Horizontal Thru ON Surface)

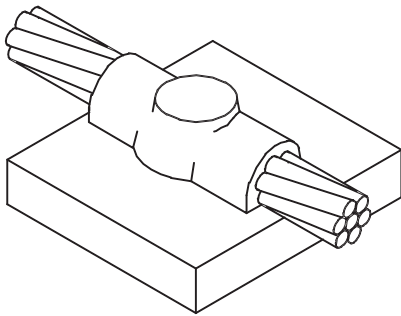

NOTES:

- For CAHT molds, a mold sealer may be required when welding conductors 1/0 and larger.

CAHT Connection Type

Conductor Size	Surface	Part No.	Weld Metal
#14 to #10 Solid (use sleeve ADPSLV6)* or #8 Solid or Stranded or #6 Solid	Flat (12" & larger pipe)	CAHT6SA	NUWTUBE25CA
	3/4" to 2" pipe	CAHT6SH.75X2A	
	2-1/2" to 5" pipe	CAHT6SH2.5X5A	
	6" to 10" pipe	CAHT6SH6X10A	
6 Stranded	Flat (12" & larger pipe)	CAHT6A	
	3/4" to 2" pipe	CAHT6H.75X2A	
	2-1/2" to 5" pipe	CAHT6H2.5X5A	
	6" to 10" pipe	CAHT6H6X10A	
4 Solid	Flat (12" & larger pipe)	CAHT4SA	
	3/4" to 2" pipe	CAHT4SH.75X2A	
	2-1/2" to 5" pipe	CAHT4SH2.5X5A	
	6" to 10" pipe	CAHT4SHX10A	
4 Stranded	Flat (12" & larger pipe)	CAHT4A	
	3/4" to 2" pipe	CAHT4H.75X2A	
	2-1/2" to 5" pipe	CAHT4H2.5X5A	
	6" to 10" pipe	CAHT4H6X10A	
2 Solid	Flat (14" & larger pipe)	CAHT2SA	NUWTUBE32CA
	2" to 3-1/2" pipe	CAHT2SH2X3.5A	
	4" to 6" pipe	CAHT2SH4X6A	
	8" to 12" pipe	CAHT2SH8X10A	
2 Stranded	Flat (18" & larger pipe)	CAHT2A	NUWTUBE45CA
	2" to 3-1/2" pipe	CAHT2H2X3.5A	
	4" to 8" pipe	CAHT2H4X8A	
	10" to 16" pipe	CAHT2H10X16A	
1 Stranded	Flat (18" & larger pipe)	CAHT1A	NUWTUBE45CA
	2" to 3-1/2" pipe	CAHT1H2X3.5A	
	4" to 8" pipe	CAHT1H4X8A	
	10" to 16" pipe	CAHT1H10X16A	
1/0 Stranded	Flat (30" & larger pipe)	CAHT1/0A	NUWTUBE65CA
	3" to 4" pipe	CAHT1/0H3X4A	
	5" to 6" pipe	CAHT1/0H5X6A	
	8" to 10" pipe	CAHT1/0H8X10A	
	12" to 28" pipe	CAHT1/0H12X28A	
2/0 Stranded	Flat (30" & larger pipe)	CAHT2/0A	NUWTUBE65CA
	3" to 4" pipe	CAHT2/0H3X4A	
	5" to 6" pipe	CAHT2/0H5X6A	
	8" to 10" pipe	CAHT2/0H8X10A	
	12" to 28" pipe	CAHT2/0H12X28A	

Mold Information:

- CAVA mold - cable is at 45 degrees to vertical steel surface.
- Price Key "L, M, and N" molds include a MH3 handle and flint igniter.
- Price Key is the **Bold Letter** in the Mold Part No.

Recommended Tools & Accessories:

- RASP - Metal Rasp
- CCBRSH1 - Card Cloth Brush
- MCBRSH1 - Large Mold Cleaning Brush
- MCBRSH2 - Small Mold Cleaning Brush
- MLDSLR - Mold Sealer (1/0 and Larger)
- CMCSPD - Cleaning Spade
- CSKITVPH3 - Chain Support Kit - Vertical Pipe

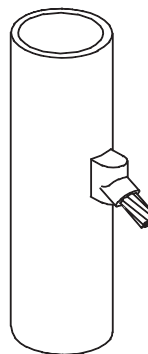

CAVA
(Cathodic Vertical Angle 45°)

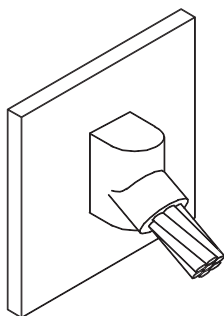

NOTES:

- For **CAVA** molds, a mold sealer may be required when welding conductors 1/0 and larger.

CAVA Connection Type

Conductor Size	Surface	Part No.	Weld Metal
#14 to #10 Solid (use sleeve ADPSLV6)* or #8 Solid or Stranded or #6 Solid	Flat (12" & larger pipe)	CAVA6SL	NUWTUBE15CA
	3/4" to 3-1/2" pipe	CAVA6SV.75X3.5L	
	4" to 10" pipe	CAVA6SV4X10L	
6 Stranded	Flat (12" & larger pipe)	CAVA6L	
	3/4" to 3-1/2" pipe	CAVA6V.75X3.5L	
	4" to 10" pipe	CAVA6V4X10L	
4 Solid	3/4" to 1-1/2" pipe	CAVA4SV.75X1.5L	NUWTUBE25CA
	Flat (12" & larger pipe)	CAVA4SL	
	2" to 4" pipe	CAVA4SV2X4L	
	5" to 10" pipe	CAVA4SV5X10L	
4 Stranded	3/4" to 1-1/2" pipe	CAVA4V.75X1.5L	
	Flat (12" & larger pipe)	CAVA4L	
	2" to 4" pipe	CAVA4V2X4L	
2 Solid	5" to 10" pipe	CAVA4V5X10L	
	Flat (14" & larger pipe)	CAVA2SL	NUWTUBE32CA
	1" to 1-1/2" pipe	CAVA2SV1X1.5L	
	2" to 4" pipe	CAVA2SV2X4L	
5" to 12" pipe	CAVA2SV5X12L		
2 Stranded	Flat (14" & larger pipe)	CAVA2L	NUWTUBE45CA
	1" to 1-1/2" pipe	CAVA2V1X1.5L	
	2" to 3" pipe	CAVA2V2X3L	
	4" to 6" pipe	CAVA2V4X6L	
1 Stranded	8" to 12" pipe	CAVA2V8X12L	NUWTUBE65CA
	Flat (18" & larger pipe)	CAVA1M	
	1-1/2" to 2-1/2" pipe	CAVA1V1.5X2.5M	
	3" to 4" pipe	CAVA1V3X4M	
1/0 Stranded	5" to 10" pipe	CAVA1V5X10M	NUWTUBE65CA
	12" to 16" pipe	CAVA1V12X16M	
	Flat (18" & larger pipe)	CAVA1/0M	
	2-1/2" to 4" pipe	CAVA1/0V2.5X4M	
2/0 Stranded	5" to 10" pipe	CAVA1/0V5X10M	NUWTUBE65CA
	12" to 16" pipe	CAVA1/0V12X16M	
	Flat (18" & larger pipe)	CAVA2/0M	
	3" to 4" pipe	CAVA2/0V3X4M	
2/0 Stranded	5" to 10" pipe	CAVA2/0V5X10M	NUWTUBE65CA
	12" to 16" pipe	CAVA2/0V12X16M	
	Flat (18" & larger pipe)	CAVA2/0M	

Mold Information:

- **CAVDO** mold - cable is **on** the steel surface.
- If a weld is on the side of a horizontal steel pipe, contact factory for proper part number.
- Price Key "**A**" Molds include Frame and Flint Igniter.
- Price Key is the **Bold Letter** in the Mold Part No.
Example: CAVA6SL

Recommended Tools & Accessories:

- CCBRSH1 - Card Cloth Brush
- MCBRSH1 - Large Mold Cleaning Brush
- MCBRSH2 - Small Mold Cleaning Brush
- RASP - Metal Rasp
- CMCSPD - Cleaning Spade
- CSKITVPA - Chain Support Kit - Vertical Pipe

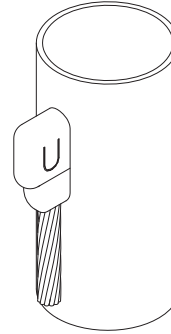

CAVDO

(Cathodic Vertical Surface
Cable Down On Surface)

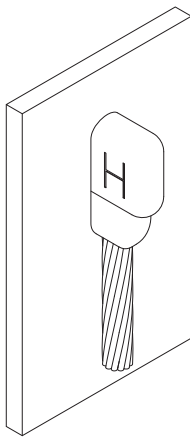

CAVDO Connection Type

Conductor Size	Surface	Part No.	Weld Metal
#14 to #10 Solid (use sleeve ADPSLV6)* or #8 Solid or Stranded or #6 Solid	Flat (12" & larger pipe)	CAVDO6SA	NUWTUBE15CA
	3/4" to 3-1/2" pipe	CAVDO6SV.75X3.5A	
	4" to 12" pipe	CAVDO6SV4X12A	
6 Stranded	Flat (12" & larger pipe)	CAVDO6A	NUWTUBE15CA
	3/4" to 3-1/2" pipe	CAVDO6V.75X3.5A	
	4" to 12" pipe	CAVDO6V4X12A	
4 Solid	Flat (12" & larger pipe)	CAVDO4SA	NUWTUBE25CA
	3/4" to 3-1/2" pipe	CAVDO4SV.75X3.5A	
	4" to 12" pipe	CAVDO4SV4X12A	
4 Stranded	Flat (12" & larger pipe)	CAVDO4A	NUWTUBE25CA
	3/4" to 3-1/2" pipe	CAVDO4V.75X3.5A	
	4" to 12" pipe	CAVDO4V4X12A	
2 Solid	Flat (12" & larger pipe)	CAVDO2SA	NUWTUBE32CA
	1" to 3-1/2" pipe	CAVDO2SV1X3.5A	
	4" to 12" pipe	CAVDO2SV4X12A	
2 Stranded	Flat (12" & larger pipe)	CAVDO2A	NUWTUBE32CA
	1" to 3-1/2" pipe	CAVDO2V1X3.5A	
	4" to 12" pipe	CAVDO2V4X12A	

Mold Information:

- **CACIHD** and **CACIHT** molds - cable is on the cast iron surface.
All cast iron molds require the use of cast iron weld metal. Example NUWTUBE25CI
- Price Key "A" Molds include Frame and Flint Igniter.
- Price Key is the **Bold Letter** in the Mold Part No.

Recommended Tools & Accessories:

- RASP - Metal Rasp
- CCBRSH1 - Card Cloth Brush
- MCBRSH1 - Large Mold Cleaning Brush
- MCBRSH2 - Small Mold Cleaning Brush
- UMMHDA - Hold Down Kit when Price Key is "A"
- CMCSPD - Cleaning Spade
- CSKITHPA - Chain Support Kit - Horizontal Pipe

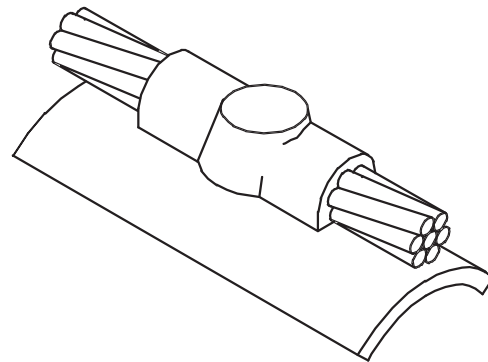

CACIHT

(Cathodic Cast Iron Horizontal Thru ON on Surface)

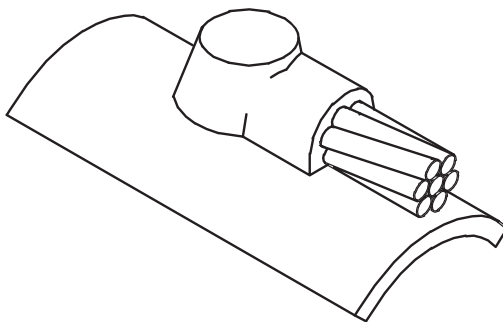

CACIHD

(Cathodic Cast Iron Horizontal Butt Down ON Surface)

Cable Size	Cast Iron Surface	Part No.	Weld Metal
#14 to #10 Solid (use sleeve ADPSLV6)* or #8 Solid or Stranded or #6 Solid	Flat and 30" pipe and larger	CACIHT6SA	NUWTUBE32CI
6 Stranded		CACIHT6A	
4 Solid		CACIHT4SA	NUWTUBE45CI
4 Stranded		CACIHT4A	
2 Solid		CACIHT2SA	
2 Stranded		CACIHT2A	

Cable Size	Cast Iron Surface	Part No.	Weld Metal
#14 to #10 Solid (use sleeve ADPSLV6)* or #8 Solid or Stranded or #6 Solid	Flat and 30" pipe and larger	CACIHD6SA	NUWTUBE25CI
6 Stranded		CACIHD6A	
4 Solid		CACIHD4SA	NUWTUBE45CI
4 Stranded		CACIHD4A	
2 Solid		CACIHD2SA	
2 Stranded		CACIHD2A	

NOTES:

- For welding **CACIHD** and **CACIHT** type welds to pipe sizes between 4" and 28" a mold is required for each size of pipe.
- For welding to CI pipes of different sizes add a "H" and pipe diameter after the cable designation and before the price key. Example: for a connection made with #2 solid to a 20" cast iron pipe, the mold number would be CACID2SH20A.

Mold Information:

- **CACIVA** mold - cable is at a **45 degree angle** to the cast iron surface. All cast iron molds require the use of cast iron weld metal. Example NUWTUBE25CI
- **CACIVDO** mold - cable is **on** the cast iron surface. All cast iron molds require the use of cast iron weld metal. Example NUWTUBE25CI
- Price Key "**L**", "**M**", and "**N**" molds include a MH3 handle and flint igniter.
- Price Key "**A**" Molds include Frame and Flint Igniter.
- Price Key is the **Bold Letter** in the Mold Part No.

Recommended Tools & Accessories:

- RASP - Metal Rasp
- CCBRSH1 - Card Cloth Brush
- MCBRSH1 - Large Mold Cleaning Brush
- CMCSPD - Cleaning Spade
- CSKITVPH3 - Chain Support Kit - Vertical Pipe

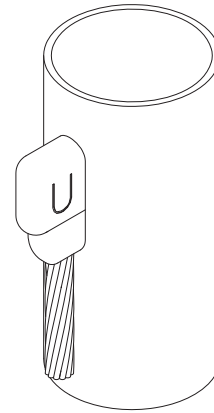

CACIVDO

(Cathodic Cast Iron Vertical Surface
Cable Down On Surface)

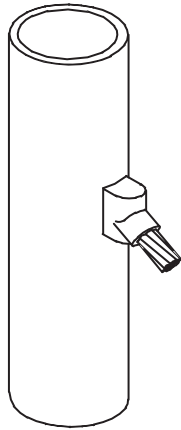

CACIVA

(Cathodic Cast Iron Vertical
Angle 45°)

Cable Size	Cast Iron Surface	Part No.	Weld Metal
#14 to #10 Solid (use sleeve ADPSLV6)* or #8 Solid or Stranded or #6 Solid	Flat and 30" pipe and larger	CACIVDO6SA	NUWTUBE25CI
6 Stranded		CACIVDO6A	
4 Solid		CACIVDO4SA	NUWTUBE32CI
4 Stranded		CACIVDO4A	
2 Solid		CACIVDO2SA	NUWTUBE45CI
2 Stranded		CACIVDO2A	

Cable Size	Cast Iron Surface	Part No.	Weld Metal
#14 to #10 Solid (use sleeve ADPSLV6)* or #8 Solid or Stranded or #6 Solid	Flat and 30" pipe and larger	CACIVA6SL	NUWTUBE25CI
6 Stranded		CACIVA6L	
4 Solid		CACIVA4SL	NUWTUBE32CI
4 Stranded		CACIVA4L	
2 Solid		CACIVA2SM	NUWTUBE45CI
2 Stranded		CACIVA2M	

NOTES:

- For welding **CACIVA** and **CACIVDO** type welds to pipe sizes between 4" and 28" a mold is required for each size of pipe.
- For welding to CI pipes of different sizes add a "**V**" and pipe diameter after the cable designation and before the price key. Example: for a connection made with #2 solid to a 20" cast iron pipe, the mold number would be CACIHD2SV20A.

Mold Information:

- **CART** molds – cable run and tap molds
- Price Key "L, M, and N" molds include a MH3 handle and flint igniter.
- Price Key is the **Bold Letter** in the Mold Part No.

Recommended Tools & Accessories:

- CCBRSH1 - Card Cloth Brush
- MCBRSH1 - Large Mold Cleaning Brush
- MCBRSH2 - Small Mold Cleaning Brush
- CMCSPD - Cleaning Spade

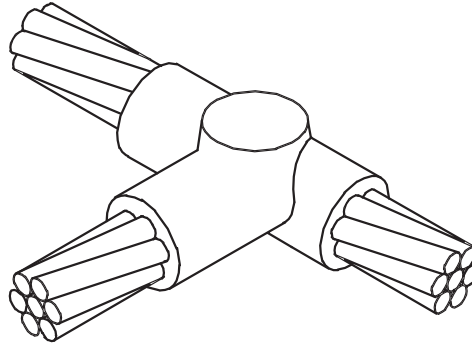

CART
(Cathodic Run & Tap)

CART Connection Type

Conductor Size	Surface	Part No.	Weld Metal
6 Stranded	6 Stranded	CART66N	NUWTUBE32CA
4 Stranded	4 Stranded	CART44N	
2 Solid	2 Solid	CART252SN	NUWTUBE45CA
2 Stranded	6 Stranded	CART26N	
	4 Stranded	CART24N	
	2 Solid	CART22SN	
	2 Stranded	CART22N	
1/0 Stranded	6 Stranded	CART1/06N	
	4 Stranded	CART1/04N	
	2 Solid	CART1/02SN	
	2 Stranded	CART1/02N	
2/0 Stranded	6 Stranded	CART2/06N	
	4 Stranded	CART2/04N	
	2 Solid	CART2/02SN	
	2 Stranded	CART2/02N	

Mold Information:

- **CABS** molds - cable to cable butt splices
- **CAPB** molds are cable to cable parallel splices.
- Price Key "L, M, and N" molds include a MH3 handle and flint igniter.
- Price Key is the **Bold Letter** in the Mold Part No.

Recommended Tools & Accessories:

- CCBRSH1 - Card Cloth Brush
- MCBRSH1 - Large Mold Cleaning Brush
- MCBRSH2 - Small Mold Cleaning brush
- CMCSPD - Cleaning Spade

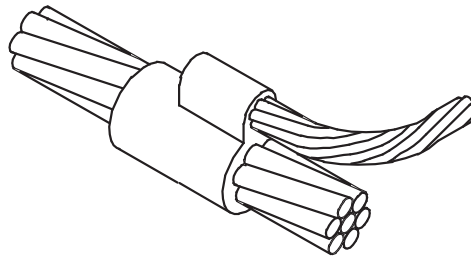

CAPB
(Cathodic Parallel Butt)

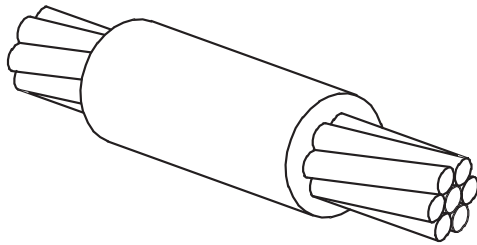

CABS
(Butt Splice Cables)

CABS Connection Type

Conductor Size	Part No.	Ultraweld Number
12 Solid	CABS12S12SL	NUWTUBE15CA
10 Solid	CABS10S10SL	
8 Solid	CABS8S8SL	
6 Solid	CABS6S6SL	NUWTUBE25CA
6 Stranded	CABS66L	
4 Solid	CABS4S4SL	
4 Stranded	CABS44L	
2 Solid	CABS2S2SL	NUWTUBE32CA
2 Stranded	CABS22L	
1 Stranded	CABS11L	NUWTUBE45CA
1/0 Stranded	CABS1/01/0M	
2/0 Stranded	CABS2/02/0M	

CAPB Connection Type

Conductor Size	Surface	Part No.	Weld Metal
6 Stranded	8 Solid	CAPB68SL	NUWTUBE25CA
	8 Stranded	CAPB68L	
	6 Solid	CAPB66SL	
	6 Stranded	CAPB66L	
4 Stranded	8 Solid	CAPB48SL	NUWTUBE32CA
	8 Stranded	CAPB48L	
	6 Solid	CAPB46SL	
	6 Stranded	CAPB46L	
	4 Stranded	CAPB44L	
2 Stranded	8 Solid	CAPB28SL	NUWTUBE45CA
	8 Stranded	CAPB28L	
	6 Solid	CAPB26SL	
	6 Stranded	CAPB26L	
	4 Stranded	CAPB24M	
1 Stranded	2 Stranded	CAPB22M	NUWTUBE65CA
	8 Solid	CAPB18SM	NUWTUBE45CA
	8 Stranded	CAPB18M	
	6 Solid	CAPB16SM	
	6 Stranded	CAPB16M	
	4 Stranded	CAPB14M	
2 Stranded	CAPB12M	NUWTUBE65CA	
1/0 Stranded	8 Solid	CAPB1/08SM	NUWTUBE45CA
	8 Stranded	CAPB1/08M	
	6 Solid	CAPB1/06SM	
	6 Stranded	CAPB1/06M	
	4 Stranded	CAPB1/04M	
	2 Stranded	CAPB1/02M	
2/0 Stranded	8 Solid	CAPB2/08SM	
	8 Stranded	CAPB2/08M	
	6 Solid	CAPB2/06SM	
	6 Stranded	CAPB2/06M	
4 Stranded	CAPB2/04M	2XNUWTUBE45CA	
2 Stranded	CAPB2/02N		

Molds

Mold Information:

- CAPS molds - parallel thru splice of horizontal cables
- CAPT molds - parallel thru splice of horizontal cables, tap conductor over run.
- Price Key "L, M, and N" molds include a MH3 handle and flint igniter.
- Price Key is the **Bold Letter** in the Mold Part No.

Recommended Tools & Accessories:

- CCBRSH1 - Card Cloth Brush
- MCBRSH1 - Large Mold Cleaning Brush
- MCBRSH2 - Small Mold Cleaning Brush
- CMCSPD - Cleaning Spade

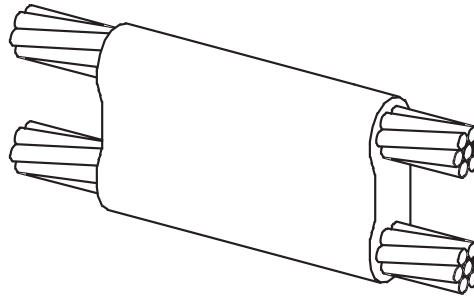

CAPT
(Cathodic Parallel Thru Cables)

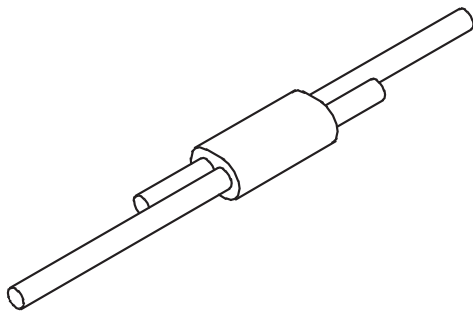

CAPS
(Cathodic Parallel Splice)

CAPS Connection Type

Cable Size		Part No.	Weld Metal
Run	Tap		
8 Solid	8 Solid	CAPS8S8SL	NUWTUBE15CA
8 Stranded	8 Stranded	CAPS88L	
6 Solid	6 Solid	CAPS6S6SL	NUWTUBE25CA
6 Stranded	6 Stranded	CAPS66L	
4 Solid	4 Solid	CAPS4S4SM	NUWTUBE32CA
4 Stranded	4 Stranded	CAPS44M	
2 Solid	2 Solid	CAPS2S2SM	NUWTUBE45CA

CAPT Connection Type

Cable Size		Part No.	Weld Metal		
Run	Tap				
6 Stranded	6 Stranded	CAPT66L	NUWTUBE25CA		
4 Stranded	8 Solid	CAPT48SL	NUWTUBE32CA		
	8 Stranded	CAPT48L			
	6 Solid	CAPT46SL			
	6 Stranded	CAPT46L			
4 Stranded	4 Stranded	CAPT44L	NUWTUBE32CA		
	2 Solid	CAPT2S2SM		NUWTUBE65CA	
	2 Stranded	8 Solid		CAPT28SM	NUWTUBE45CA
		8 Stranded		CAPT28M	
6 Solid		CAPT26SM			
6 Stranded		CAPT26M	NUWTUBE65CA		
4 Stranded		CAPT24M			
2 Solid		CAPT22SM			
2 Stranded	2 Stranded	CAPT22M	NUWTUBE65CA		
	8 Solid	CAPT1/08SM			
	8 Stranded	CAPT1/08M			
	6 Solid	CAPT1/06SM			
	6 Stranded	CAPT1/06M			
	4 Stranded	CAPT1/04M			
	2 Solid	CAPT1/02SM			
2 Stranded	CAPT1/02M				
1/0 Stranded	1/0 Stranded	CAPT1/01/0SM	NUWTUBE65CA		
	8 Solid	CAPT2/08SM			
	8 Stranded	CAPT2/08M			
	6 Solid	CAPT2/06SM		2XNUWTUBE45CA	
	6 Stranded	CAPT2/06M			
	4 Stranded	CAPT2/04M			
	2 Solid	CAPT2/02SM			
	2 Stranded	CAPT2/02M			
	1/0 Stranded	CAPT2/01/0M			
	2/0 Stranded	CAPT2/02/0M			

Molds

Mold Information:

- Molds listed are for Copper Clad Ground Rods. For threaded sectional rods, add suffix "S" after the ground rod number. i.e. 58S = 5/8" sectional ground rod.
- Price Key "L, M, and N" molds include a MH3 handle and flint igniter.
- Price Key is the **Bold Letter** in the Mold Part No.

Recommended Tools & Accessories:

- CCBRSH1 - Card Cloth Brush
- MCBRSH1 - Large Mold Cleaning Brush
- MCBRSH2 - Small Mold Cleaning Brush
- CMCSPD - Cleaning Spade

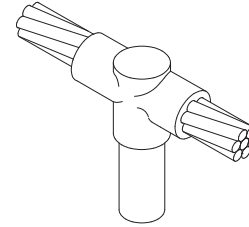

CAGO

(Cathodic Ground Rod to Cable Over Top)

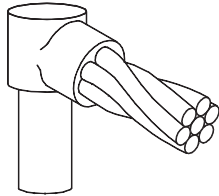

CAGD

(Cathodic Ground Rod to Dead End Cable)

Cable Size	Cast Iron Surface	Part No.	Weld Metal		
1/2 Full Copper Clad (.500)	#14 to #10 Solid (use sleeve ADPSLV6)* or #8 Solid or Stranded or #6 Solid	CAGD12F6SL	NUWTUBE25CA		
	6 Stranded	CAGD12F6L			
	4 Solid	CAGD12F4SL			
	4 Stranded	CAGD12F4L			
	5/8 Nominal Copper Clad (.563)	2 Solid	CAGD12F2SL	NUWTUBE32CA	
		2 Stranded	CAGD12F2L		
		1 Stranded	CAGD12F1M	NUWTUBE45CA	
		1/0 Stranded	CAGD12F1/0M	NUWTUBE65CA	
		2/0 Stranded	CAGD12F2/0M		
		5/8 Nominal Copper Clad (.563)	#14 to #10 Solid (use sleeve ADPSLV6)* or #8 Solid or Stranded or #6 Solid	CAGD586SL	NUWTUBE32CA
6 Stranded			CAGD586L		
4 Solid			CAGD584SL		
4 Stranded	CAGD584L				
3/4 Nominal Copper Clad (.682)	2 Solid		CAGD582SM	NUWTUBE45CA	
	2 Stranded		CAGD582M		
	1 Stranded		CAGD581M	NUWTUBE65CA	
	1/0 Stranded		CAGD581/0M		
	3/4 Nominal Copper Clad (.682)		2/0 Stranded	CAGD582/0M	NUWTUBE32CA
			#14 to #10 Solid (use sleeve ADPSLV6)* or #8 Solid or Stranded or #6 Solid	CAGD346SL	
6 Stranded		CAGD346L			
4 Solid		CAGD344SM			
3/4 Nominal Copper Clad (.682)		4 Stranded	CAGD344M	NUWTUBE45CA	
		2 Solid	CAGD342SM		
		2 Stranded	CAGD342M	NUWTUBE65CA	
		1 Stranded	CAGD341M		
		1/0 Stranded	CAGD341/0M	NUWTUBE65CA	
		2/0 Stranded	CAGD342/0M		

Cable Size	Cast Iron Surface	Part No.	Weld Metal		
1/2 Full Copper Clad (.500)	#14 to #10 Solid (use sleeve ADPSLV6)* or #8 Solid or Stranded or #6 Solid	CAGO12F6SL	NUWTUBE32CA		
	6 Stranded	CAGO12F6L			
	4 Solid	CAGO12F4SL			
	4 Stranded	CAGO12F4L			
	5/8 Nominal Copper Clad (.563)	2 Solid	CAGO12F2SM	NUWTUBE45CA	
		2 Stranded	CAGO12F2M		
		1 Stranded	CAGO12F1M	NUWTUBE65CA	
		1/0 Stranded	CAGO12F1/0M		
5/8 Nominal Copper Clad (.563)	2/0 Stranded	CAGO12F2/0M	NUWTUBE45CA		
	#14 to #10 Solid (use sleeve ADPSLV6)* or #8 Solid or Stranded or #6 Solid	CAGO586SM			
	6 Stranded	CAGO586M			
	4 Solid	CAGO584SM			
	3/4 Nominal Copper Clad (.682)	4 Stranded	CAGO584M	NUWTUBE65CA	
		2 Solid	CAGO582SM		
		2 Stranded	CAGO582M	2XNUWTUBE45CA	
		1 Stranded	CAGO581M		
		3/4 Nominal Copper Clad (.682)	1/0 Stranded	CAGO581/0N	NUWTUBE45CA
			2/0 Stranded	CAGO582/0N	
3/4 Nominal Copper Clad (.682)	#14 to #10 Solid (use sleeve ADPSLV6)* or #8 Solid or Stranded or #6 Solid		CAGO346SM	NUWTUBE45CA	
	6 Stranded		CAGO346M		
	4 Solid		CAGO344SM	NUWTUBE65CA	
	4 Stranded		CAGO344M		
3/4 Nominal Copper Clad (.682)	2 Solid		CAGO342SM	2XNUWTUBE45CA	
	2 Stranded		CAGO342M		
	1 Stranded	CAGO341M	NUWTUBE65CA		
	1/0 Stranded	CAGO341/0N			
3/4 Nominal Copper Clad (.682)	2/0 Stranded	CAGO342/0N	2XNUWTUBE45CA		

Molds

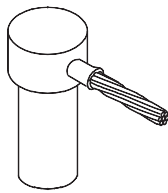

G11

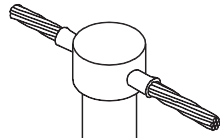

G21

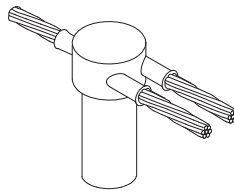

G31

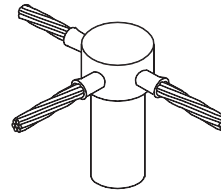

G31*

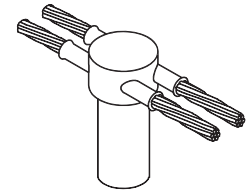

G41

NUWTube Uni-Shots

Type	Cable Sizes		Ground Rod			
	Solid	Stranded	5/8 Copper Clad	5/8 Full	3/4 Copper Clad	3/4 Full
G11	#6, #8	#8	G11588NU	G1158F8NU	G11348NU	G1134F8NU
G11	#3, #4	#4, #6	G11584NU	G1158F4NU	G11344NU	G1134F4NU
G11	#1, #2	#2, #3	G11582NU	G1158F2NU	G11342NU	G1134F2NU
G11	2/0, 1/0	1/0, #1	G11581/0NU	G1158F1/0NU	G11341/0NU	G1134F1/0NU
G11	-	2/0	G11582/0NU	G1158F2/0NU	G11342/0NU	G1134F2/0NU
G21	#6, #8	#8	G21588NU	G2158F8NU	G21348NU	G2134F8NU
G21	#3, #4	#4, #6	G21584NU	G2158F4NU	G21344NU	G2134F4NU
G21	#1, #2	#2, #3	G21582NU	G2158F2NU	G21342NU	G2134F2NU
G21	2/0, 1/0	1/0, #1	G21581/0NU	G3158F1/0NU	G21341/0NU	G2134F1/0NU
G31	#6, #8	#8	G31588NU	G3158F8NU	G31348NU	G3134F8NU
G31	#3, #4	#4, #6	G31584NU	G3158F4NU	G31344NU	G3134F4NU
G31	#1, #2	#2, #3	G31582NU	G3158F2NU	G31342NU	G3134F2NU
G31	2/0, 1/0	1/0, #1	G31581/0NU	G3158F1/0NU*	G31341/0NU	G3134F1/0NU*
G41	#6, #8	#8	G41588NU	G4158F8NU	G41348NU	G4134F8NU
G41	#3, #4	#4, #6	G41584NU	G4158F4NU	G41344NU	G4134F4NU
G41	#1, #2	#2, #3	G41582NU	G4158F2NU	G41342NU	G4134F2NU

NOTES:

- Disposable single use ceramic mold provides convenience and ease of use. Packaged 12 per box.
- Requires only a Flint Igniter (FLTIG) to make a connection. See Page 26.
- No frames or handle clamps are required.

Use locking pliers to support mold



NUWTube
(Traditional)



Mold Information:

- Price Key "L, M, and N" molds include a MH3 handle and flint igniter.
- Price Key is the **Bold Letter** in the Mold Part No.

Recommended Tools & Accessories:

- CCBRSH1 - Card Cloth Brush
- MCBRSH1 - Large Mold Cleaning Brush
- MCBRSH2 - Small Mold Cleaning Brush
- CMCSPD - Cleaning Spade

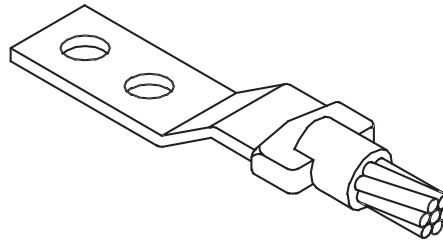

CALE

(Cathodic Lug End)

CALE Connection Type

Conductor Size	Lug Dimensions	Part No.	Weld Metal
#14 to #10 Solid (use sleeve ADPSLV6)* or #8 Solid or Stranded or #6 Solid	1/16 X 1/2 LUG	CALE6S11612L	NUWTUBE25CA
6 Stranded		CALE611612L	
4 Solid		CALE4S11612L	
4 Stranded		CALE411612L	NUWTUBE32CA
2 Solid		CALE2S11612L	
2 Stranded		CALE211612L	
1 Stranded		CALE111612L	NUWTUBE45CA
1/0 Stranded		CALE1/011612M	
2/0 Stranded	1/8 X 1 LUG	CALE2/0181M	

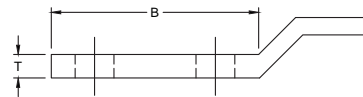
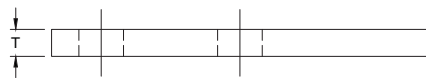
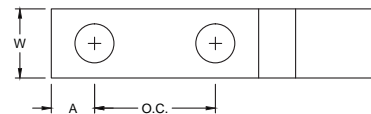
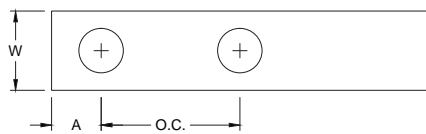
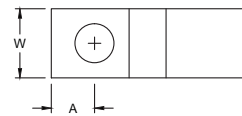
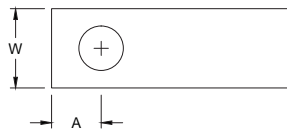

STRAIGHT

OFFSET

Lug Size	Straight P/N	Offset P/N	Number of Holes	Screw Size	O.C. Dimension	T	W	A	B
1/16 x 1/2	SXL11612	OXL11612	1	1/4	N/A	1/16	1/2	1/2	7/8
	SXL116122A	OXL116122A	2		0.625			5/8	3
1/8 x 1	SXL181	OXL181	1	3/8	N/A	1/8	1	1/2	7/8
	SXL1812B	OXL1812B	2		0.75			5/8	3

Mold Information:

- **CAHDFB** Molds are for cable in a field made formed sleeve to steel surface or pipe.
- **CACIHDFB** Molds are for cable in a field made formed sleeve to cast iron surface or pipe. These welds require the use of cast iron powder.
- Price Key "A" Molds includes Frame and Flint Igniter.
- Price Key is the **Bold Letter** in the Mold Part No.

Required Tools & Accessories:

Hammer Die as specified by cable size
Sleeve as specified by cable size

Recommended Tools & Accessories:

- CCBRSH1 - Card Cloth Brush
- MCBRSH1 - Large Mold Cleaning Brush
- MCBRSH2 - Small Mold Cleaning Brush
- CMCSPD - Cleaning Spade
- CSKITHPA - Chain Support Kit - Horizontal Pipe

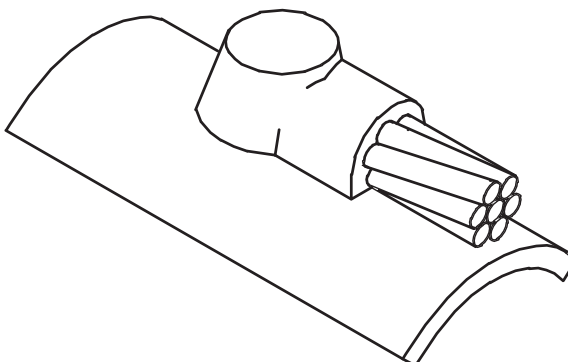

CAHDFB

(Cathodic Horizontal Butt Down
in Field made Bond ON Surface)

CACIHDFB

(Cathodic Cast Iron Horizontal Butt Down
in Field made Bond ON Surface)

CAHDFB Connection Type

Wire Size	Pipe Size	Part No.	Weld Metal
4 Stranded IN FB	4" pipe	CAHDFB4H4A	NUWTUBE25CA
	6" to 8" pipe	CAHDFB4H6X8A	
	10" and larger	CAHDFB4A	
2 Stranded IN FB	4" pipe	CAHDFB2H4A	
	6" to 8" pipe	CAHDFB2H6X8A	
	10" and larger	CAHDFB2A	
1 Stranded IN FB	4" pipe	CAHDFB1H4A	NUWTUBE32CA
	6" to 8" pipe	CAHDFB1H6X8A	
	10" and larger	CAHDFB1A	
1/0 Stranded IN FB	4" pipe	CAHDFB1/0H4A	
	6" to 8" pipe	CAHDFB1/0H6X8A	
	10" and larger	CAHDFB1/0A	
2/0 Stranded IN FB	4" pipe	CAHDFB2/0H4A	NUWTUBE45CA
	6" to 8" pipe	CAHDFB2/0H6X8A	
	10" and larger	CAHDFB2/0A	

CACIHDFB Connection Type

Wire Size	Pipe Size	Part No.	Weld Metal
4 Stranded IN FB	4" to 28" Pipe	CACIHDFB4H**A	NUWTUBE45CI
	30" and larger	CACIHDFB4A	
2 Stranded IN FB	4" to 28" Pipe	CACIHDFB2H**A	
	30" and larger	CACIHDFB2A	
1 Stranded IN FB	4" to 28" Pipe	CACIHDFB1H**A	NUWTUBE32CI
	30" and larger	CACIHDFB1A	
1/0 Stranded IN FB	4" to 28" Pipe	CACIHDFB1/0H**A	
	30" and larger	CACIHDFB1/0A	
2/0 Stranded IN FB	4" to 28" Pipe	CACIHDFB2/0H**A	
	30" and larger	CACIHDFB2/0A	

NOTES:

- For **CACIHDFB** welds to pipes in the range from 4" to 28" you must replace the "***" with the nominal pipe size in inches.

Hammer Dies

Bonds can be made in the field using your own cable, an adaptor sleeve, and a hammer die designed for that size cable. Please see the table for suggested sleeve and hammer die part numbers.

Wire Size	Hammer Die #	Sleeve
#4 Str	Not required	ADPSLV2B
#2 Str	HMDIE2	ADPSLV1
#1 Str	HMDIE1	ADPSLV4/0
1/0 Str	HMDIE1/0	ADPSLV4/0
2/0 Str	HMDIE2/0	ADPSLV4/0

Copper Strap Bonds

The copper strap bond is used to provide continuity across pipe joints. The strap bond is made of soft copper strip 1-1/4" wide that provides equivalent conductivity to 1/0 wire. Applications can call for a variety of hole patterns. If you can't find the proper one here, don't hesitate to request a special pattern.

Mold required for strap bonds is a **CASBHPA**. This mold requires Weld Metal NUWTUBE15CA.

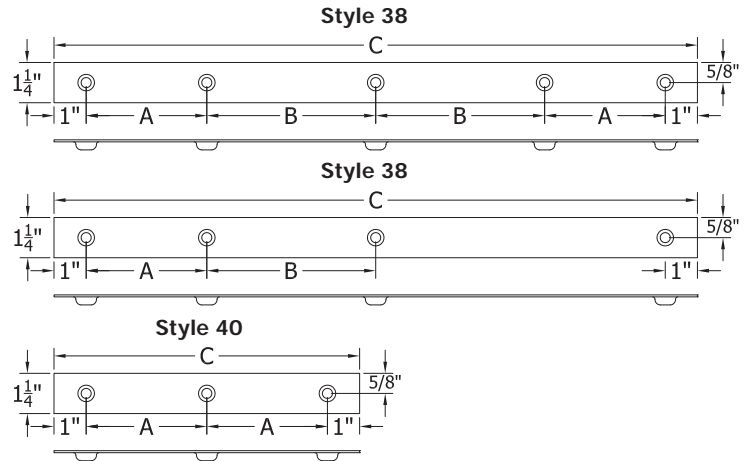

Coupling Size	Style	Part No.	# of Holes	A	B	C	
5" and Larger Pipe	38	SB4L20	4	3-3/4"	5-1/4"	20"	
		SB4L22		3-3/4"	6-1/4"	22"	
		SB5L20	5	3-3/4"	5-1/4"	20"	
		SB5L22		3-3/4"	6-1/4"	22"	
Under 5" & Light Pattern		38	SB4S17	4	3-1/4"	4-1/4"	17"
			SB4S19		3-1/4"	5-1/4"	19"
			SB5S17	5	3-1/4"	4-1/4"	17"
			SB5S19		3-1/4"	5-1/4"	19"
All style 40 couplings require two SB3A9.5 Strap Bonds	40		SB3A9.5	3	3-3/4"	NA	9-1/2"

Copper Jumper Bonds

Factory made jumper bonds have copper sleeves formed on each end. These are most commonly used across pipe joints. Formed ends allow the use of smaller weld metal cartridges.

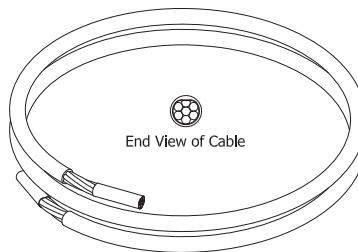

Jumper Bond Descriptions		
Conductor Size	Length	Part No.
#4 Str	18"	CAJB4X18
	24"	CAJB4X24
#2 Str	18"	CAJB2X18
	24"	CAJB2X24

Conductor Size	Jumper Bond Molds for STEEL Pipes			Jumper Bond Molds for CAST IRON Pipes		
	Pipe Size	Part No.	Weld Metal	Pipe Size	Part No.	Weld Metal
#4 STR	4" Pipe	CAHDB2H4A	NUWTUBE25CA	4" to 28" Pipe	CACIHDB4H**A	NUWTUBE32CI
#4 STR	6" - 8" Pipe	CAHDB2H6X8A	NUWTUBE25CA	30" and Larger Pipe	CACIHDB4A	NUWTUBE32CI
#4 STR	10" and larger	CAHDB4A	NUWTUBE25CA	Replace "***" with Pipe Size		
#2 STR	4" Pipe	CAHDB2H4A	NUWTUBE25CA	#2 STR	CACIHDB2H**A	NUWTUBE32CI
#2 STR	6" - 8" Pipe	CAHDB2H6X8A	NUWTUBE25CA	#2 STR	CACIHDB2A	NUWTUBE32CI
#2 STR	10" and larger	CAHDB2A	NUWTUBE25CA	Replace "***" with Pipe Size		

Molds

Ultraweld molds are made from a semi-permanent graphite that will last 50 or more welds if properly cared for.



NUWTube®

- The weld metal, a mixture of copper oxide and aluminum, is packaged in individual, moisture resistant plastic tubes.
- Dual chamber design holds starting material and weld metal separately, in the same tube.
- Easy to identify with color coded caps. Clear = Weld Metal, Orange = Starting Material.
- Each cartridge is marked with the size.
- Each box also contains instructions and metal disks. One metal disk is used for each connection.

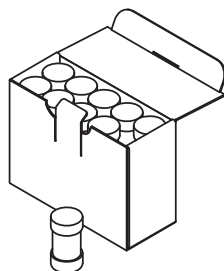

NUWTube® (Pour & Shoot) Weld Metal

Size	Qty. Per Carton
NUWTUBE15CA	20
NUWTUBE25CA	20
NUWTUBE32CA	20
NUWTUBE45CA	20
NUWTUBE65CA	20

Cast Iron NUWTube®

- For use on ductile iron surfaces.
- Dual chamber design holds starting material and weld metal separately, in the same tube.
- "Red Dot" on cap designates the starting material side.
- Each cartridge is marked with the size.
- Each box also contains instructions and metal disks. One metal disk is used for each connection.

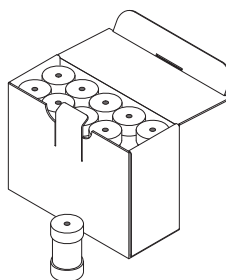

Cast Iron NUWTube® Weld Metal

Size	Qty. Per Carton
NUWTUBE25CI	20
NUWTUBE32CI	20
NUWTUBE45CI	20
NUWTUBE65CI	20

Mold Accessories

Torch Head

Part No.	Qty.	Approx. Each Wt. (lbs.)
TRCHD	EACH	2

- Self-igniting Torch Head is designed to fit 14 or 16 ounce propane cylinders.
- Torches are required to remove moisture from the mold and conductors before making the Ultraweld connections.

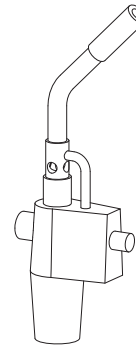

Adapting Molds to Fit Conductors

Wrap Sleeves

Part No.	Qty.	Approx. Each Wt. (lbs.)
WRPSLV	EACH	0.01

- Wrap Sleeves can be used when welding cables smaller than indicated on mold tag.
- When the cable opening in the mold is larger than the cable, copper Wrap Sleeves are wrapped around the cable until the diameter is about the same size as the mold cable opening.
- A copper Wrap Sleeve is also used for wrapping around rebar for certain connection styles.

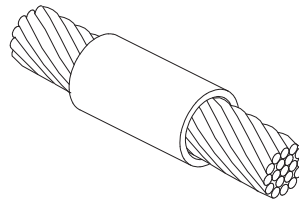
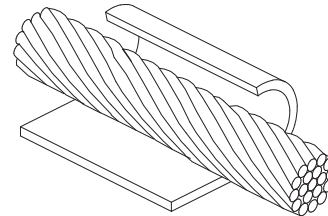

Adapter Sleeves

Part No.	Cable Size		Use in Mold for Stranded	Sleeve Dimensions			Box Qty.	Approx. Box Wt. (lbs.)
	Concentric Strand	Solid		O.D.	I.D.	Length		
ADPSLV6	#12, 14	#10, 12, 14	#6 Solid	0.156	0.111	1	25	0.25
ADPSLV4	#7, 8, 10	#6, 8	#4 Stranded	0.227	0.177	1	25	0.25
ADPSLV2A	#6	#5	#2 Stranded	0.292	0.198	1	25	0.25
ADPSLV2B	#4, 5	#3, 4	#2 Stranded	0.287	0.246	1	25	0.25
ADPSLV1	#4	n/a	#1 Stranded	0.34	0.246	1	25	0.25
ADPSLV1/0	#2	#1	1/0 Stranded	0.37	0.307	1	25	3
ADPSLV2/0	#1	1/0	2/0 Stranded	0.42	0.359	1	25	0.25

Mold Care & Use

Mold Sealer

Part No.	Qty.	Approx. Each Wt. (lbs.)
MLDSL	EACH	2

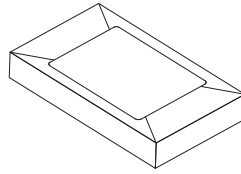

- Mold Sealer is for sealing slightly worn molds to guard against leakage from large stranded conductors.
- Available in a convenient 1 pound package.

Disks

Part No.	Description	Diameter	Box Qty.	Approx. Box Wt. (lbs.)
DISK15/65	Used in molds using 15 thru 65 weld metal	3/4"	20	0.6

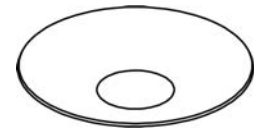

- The disk rests on the bottom of the crucible and holds the weld metal powder in place until the reaction occurs.
- A new disk is required each time a weld is made.
- Disks are included with the NUWTUBE Weld Metal.

Flint Igniter

Part No.	Description	Qty.	Approx. Each Wt. (lbs.)
FLTIG	Flint Igniter	EACH	0.21
FLTIGEXT	Flint Igniter 36" Extension		3
RPLFLT	Replacement Flint		0.01

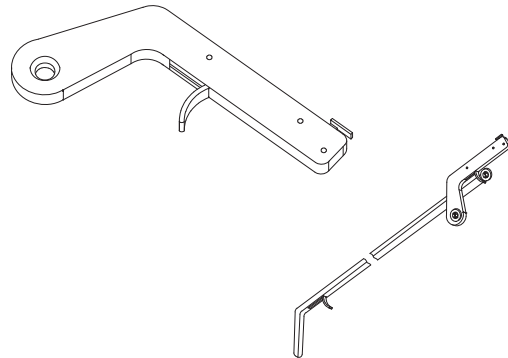

- When making an Ultraweld connection, Flint Igniters are used to ignite the starting material.
- Flint igniters come with Price Key "A" Molds or MH1 handle clamps.
- Replacement Flints are also available.

Cable & Work Surface Preparation

Cold Galvanizing Spray

Part No.	Qty.	Approx. Each Wt. (lbs.)
CGS	EACH	2



- Instant cold galvanizing spray provides protection equal to hot dip galvanizing.
- Used for touching up surfaces affected by welding.

Rasp

Part No.	Qty.	Approx. Each Wt. (lbs.)
RASP	EACH	3



- Ideal for removing mill scale and rust from steel surfaces.

Mold Fastening & Mounting

Magnetic Hold Down For A Molds

Part No.	Mold Price Key	Handle Clamp	Pipe	Approx. Each Wt. (lbs.)
UMMHDA	A	MH5	Horizontal	0.5

- Used for horizontal 'A' molds with cable exiting mold in only one direction.

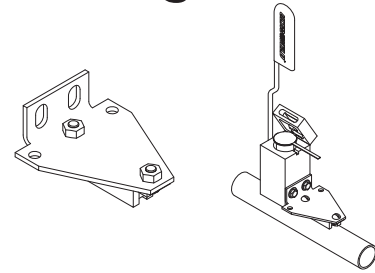

Chain Support Kit - Horizontal Pipe

Part No.	Mold Price Key	Handle Clamp	Pipe	Approx. Each Wt. (lbs.)
CSKITHPA	A	MH5	Horizontal	1

- Chain support kit used to hold down horizontal "A" molds

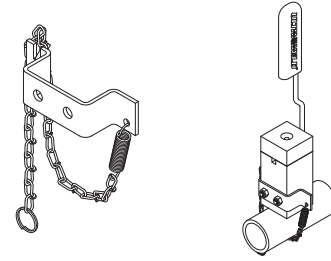

Chain Support Kit - Vertical Pipe

Part No.	Mold Price Key	Handle Clamp	Pipe	Approx. Each Wt. (lbs.)
CSKITVPA	A	MH5	Vertical	0.16

- Chain support kit used to hold down horizontal "A" molds

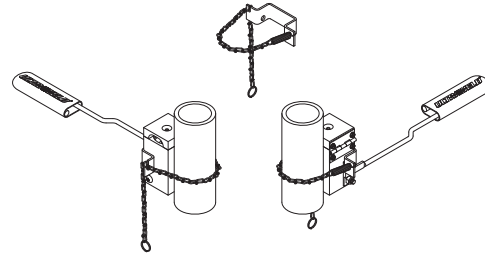

Chain Support Kit - Horizontal Pipe

Part No.	Mold Price Key	Handle Clamp	Pipe	Approx. Each Wt. (lbs.)
CSKITHPH3	L,M,N	MH3	Horizontal	0.2

- Chain support kit used to hold down horizontal "L, M, N" molds

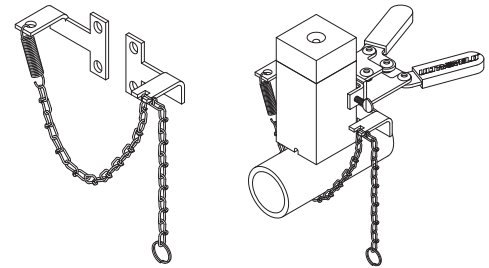

Chain Support Kit - Vertical Pipe

Part No.	Mold Price Key	Handle Clamp	Pipe	Approx. Each Wt. (lbs.)
CSKITVPH3	L,M,N	MH3	Vertical	0.2

- Chain support kit used to hold down horizontal "L, M, N" molds

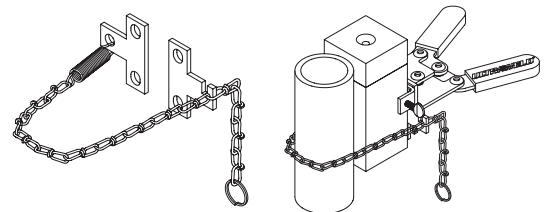

Mold Handle Clamp

Part No.	Application	Qty.	Approx. Each Wt. (lbs.)
MH3	For Combo molds with L & M mold price key	EACH	0.65
MH4	For Combo molds with R mold price key		2

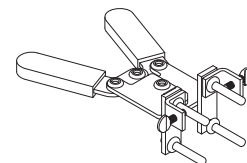

Solid Copper Conductor

Solid Single Soft-Drawn Bare Copper

Part No.	Size (AWG)	Diameter	CM Area	Approx. Wt. lbs./Reel
10	10	.101	10,380	31-1/2
8	8	.128	16,510	50
6	6	.162	26,240	80
4	4	.204	41,470	126
2	2	.257	66,360	201

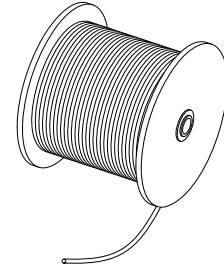

Solid Tinned Copper Conductor

Solid Single Soft-Drawn Bare Tinned Copper

Part No.	Size (AWG)	Diameter	CM Area	Approx. Wt. lbs./Reel
8T	8	.128	16,510	50
6T	6	.162	26,240	80
4T	4	.204	41,470	126
2T	2	.257	66,360	201

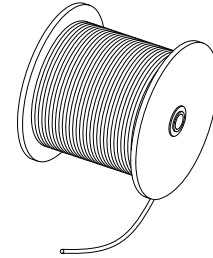

- 2T can be ordered as stock items #2T-250 (250' standard reel) and #2T-500 (500' standard reel).
- Contact factory for reel sizes/put ups.

NOTES:

- Other sizes are available. Please contact factory for special requests.
- Solid soft-drawn conductors shall meet the requirements of ASTM B-3.
- Tinned Copper conductors shall meet the requirements of ASTM B-33.

Stranded Copper Conductor

Concentric Lay Soft-Drawn Bare Copper

Part No.	Size (AWG)	No. of Strands	CM Area	Approx. Wt. lbs./M ft.
8-7	8	7	16,510	51
6-7	6	7	24,240	81
4-7	4	7	41,740	127
2-7	2	7	66,360	204
1/0-19	1/0	19	105,600	325
2/0-7	2/0	7	133,100	410
2/0-19	2/0	19	133,100	410

- Contact factory for reel sizes/put ups.

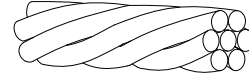

7 Strand Concentric

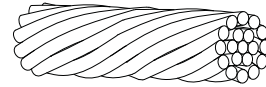

19 Strand Concentric

Green Insulated Conductor

Part No.	Size (AWG)	No. of Strands	Jacket Type	CM Area	Approx. Wt. lbs./M ft.
67G	6	7	THW	26,240	105
6-19G	6	19	THHN	26,240	98
47G	4	7	THW	41,740	160
4-19G	4	19	THHN	41,740	157
27G	2	7	THW	66,360	245
2-19G	2	19	THHN	66,360	240
1/019G	1/0	19	THHN	105,600	372
2/019G	2/0	19	THHN	133,100	462

- Contact factory for reel sizes/put ups.

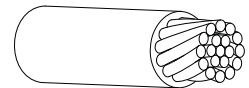

19 Strand Insulated

NOTES:

- Green Insulated conductor carries a THW or THHN rating. Other colors available upon request.
- Sizes up to 1000 MCM are available. Please contact the factory for special requests.
- Harger offers standard reel sizes, however we will cut to specified lengths.
- Bare Stranded conductor shall meet the requirements of ASTM B-8.
- Stranded copper conductors available tinned. Please add suffix T to part number.

Copper Clad Steel Ground Rod

Grounding Components

Part No.	Size	Approx. Each Wt. (lbs.)	Standard Bundle	Approx Wt. lbs./Bundle	UL Mark	With UPC Label
110	1" x 10'	23	3	69	Yes	No
1208UPC	1/2" x 8'	6	5	30	Yes	Yes
1210	1/2" x 10'	7	5	35	Yes	No
3410	3/4" x 10'	13	5	65	Yes	No
3412	3/4" x 12'	15	5	75	Yes	No
348	3/4" x 8'	11	5	55	Yes	No
5810	5/8" x 10'	9	5	45	Yes	No
5810UPC	5/8" x 10'	9	5	45	Yes	Yes
588	5/8" x 8'	6	5	30	Yes	No
588RUS	5/8" x 8'	7	5	35	Yes	No
588UPC	5/8" x 8'	7	5	35	Yes	Yes



- For more information refer to Ground Rod table on page 8.

Galvanized Steel Ground Rod

Part No.	Size	Approx. Each Wt. (lbs.)	Standard Bundle	Approx Wt. lbs./Bundle	With UPC Label
126G	1/2" x 6'	4	5	20	No
126GUPC	1/2" x 6'	4	5	20	Yes
128G	1/2" x 8'	6	5	30	No
128GUPC	1/2" x 8'	6	5	30	Yes
3410G	3/4" x 10'	15	5	75	No
348G	3/4" x 8'	12	5	60	No
5810G	5/8" x 10'	10	5	50	No
5810GUPC	5/8" x 10'	5	50	55	Yes
588G	5/8" x 8'	8	5	40	No
588GUPC	5/8" x 8'	8	5	40	Yes

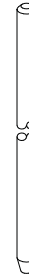

- All rods are full diameter.

NOTES:

- Manufactured from zinc coated high strength steel.
- Meets requirements of NEMA GR-1.
- Preferred electrode when primary concern is cathodic protection to structure.
- Non UL listed.

Ground Rod Driver

Part No.	Description	Ground Rod Size	Qty.	Approx. Each Wt. (lbs.)
GRD341	3/4 Replacement Insert	3/4"	EACH	12
GRD58	5/8 Ground Rod Driver & Insert	1/2" & 5/8"		25

- Drives ground rods from ground level without the need for a ladder or sledge hammer.
- 3/4" insert is interchangeable with driver body.
- Insert prevents driver from slipping off ground rod near ground level.
- Insert prevents "mushrooming" top of ground rod.

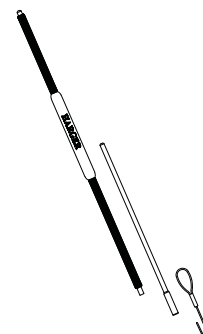

Ultrafill - Earth (Ground) Enhancement Material

Ultrafill is a low resistance carbon based backfill material, which dramatically lowers ground system resistance in difficult soil situations. Ultrafill contains no bentonite or concrete components, which, in very dry conditions, can cause shrinkage around the ground electrode, thus rendering it ineffective.

Ultrafill is ideal for use in rocky soil, sand, gravel or any other high resistance soil conditions. It is also the ideal backfill material for use around enhanced ground rods and ground grid systems.

Ultrafill is easy to use, safe and effective. Unlike other backfill products, Ultrafill is relatively dust free and does not require mixing in water prior to installation.

Ultrafill may be either used in a horizontal trench or grid, or in vertical applications. Ultrafill is available in 25 and 50 pound coated woven polypropylene bags.

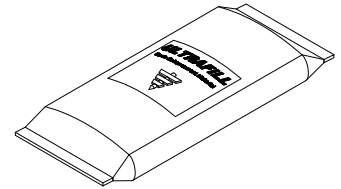

Part No.	Approx. Wt. (lbs.)
ULTRAFILL	50
ULTRAFILL25	25

Installation Instructions

Vertical Applications:

Auger hole to required depth. Insert electrode in center of hole. Pour Ultrafill to proper depth. The chart located to the right will help determine how much Ultrafill will be required.

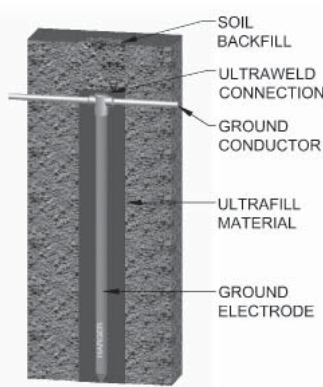

Pounds of Ultrafill Required Per Foot		
Hole Size	5/8" Ground Rod	2" EGR
4"	3.5	2.7
6"	8.1	7.3
8"	14.5	13.6
10"	22.6	21.8
12"	32.6	31.8

For example, placing a 5/8" x 10' ground rod in a 4" hole would require 35 pounds of Ultrafill. (3.5 x 10 = 35 pounds)

Horizontal Applications:

Pour enough Ultrafill to cover bottom of trench. Place the ground electrode into trench. Pour in additional Ultrafill to cover electrode to the desired depth.

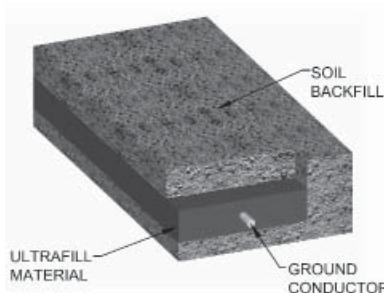

Pounds of Ultrafill Required Per Foot				
Trench Width	Thickness of Ultrafill (Inches)			
	1"	2"	3"	4"
4"	1.2	2.3	3.5	4.6
6"	1.7	3.5	5.2	6.9
8"	2.3	4.6	6.9	9.3
10"	2.5	5.8	8.7	11.6
12"	3.5	6.9	10.4	13.9

For example, using 2" of material in a 6" wide by 10' long trench would require 35 pounds of Ultrafill. (3.5 x 10 = 35 pounds)

Liquid Mixing Instructions:

To mix Ultrafill into a slurry for pumping applications, use the following formula:

- 6 parts water
- 1 part bentonite
- 1 part Ultrafill

Ground Access Wells

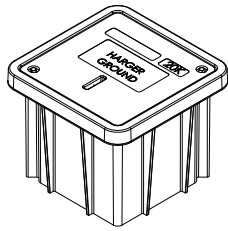

GAW121212HD

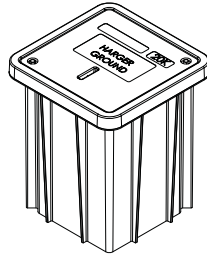

GAW121218HD

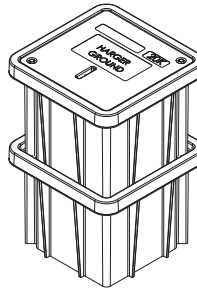

GAW121224HD*

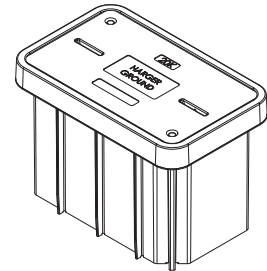

GAW132418HD

Light Weight Polymer Concrete

Part No.	Dimensions	Approx. Each Wt. (lbs.)
GAW121212HD	12" x 12" x 12" deep	28
GAW121218HD	12" x 12" x 18" deep	48
GAW121224HD	12" x 12" x 24" deep	54
GAW132418HD	13" x 24" x 18" deep	91

- Lid & Grade Ring manufactured from 20,000 PSI high density polymer concrete.
- Body manufactured from sheet molding compound for exceptional toughness and reduced weight.
- Comes with 20,000# rated covers.
- Suitable for installation and use through a temperature range of -40°C to +90°C.
- Gray color.
- * GAW121224HD is a two piece stackable, each 12" high.

ASTM C-857 Specifications

Cover Type	Cover Ratings	Live Load	30% Safety	Test Load	Test Area
Heavy Duty	10 Ton GVW (20,000#)	8,000#	10,400#	22,568#	10" x 10"
20,000# boxes and covers may be placed in locations that may see occasional non-deliberate heavy vehicles.					
Covers exceed their rating by at least 20% and exceed ASTM test loads. No polymer concrete box or cover should be placed in a full traffic, H-20, application. Meets W.U.C. 3.6.					

- GVW = Gross Vehicle Weight

Ground Access Wells

PVC Well with Cover

Part No.	Diameter	Length	Cover Type	Approx. Each Wt. (lbs.)
358PP	8"	24"	Plastic	12
358PS			Flat Steel	16
360PP	10"		Plastic	21
360PS			Flat Steel	20
362PS			Flat Steel	27

- Schedule 40 PVC well.
- Steel covers are 3/16" thick commercial grade steel with a zinc/ultraseal coating.
- Plastic covers are manufactured from High Density Polyethylene.



HDPE Well with Cover

Part No.	Diameter	Length	Cover Type	Approx. Each Wt. (lbs.)
GAW910	9"	10-1/4"	HDPE	5

- Molded High Density Polyethylene well features a 9" diameter "twist lock" cover with locking bolt.
- Static vertical load rating = 350 PSF.
- 2 knock outs (mouse holes) allow for routing conductor to the inside.
- For use in non-vehicular traffic areas.



PVC Slotted Well with Cover

Part No.	Diameter	Length	Cover Type	Approx. Each Wt. (lbs.)
358P42	8"	42"	Flat Steel	23
358PP42			Plastic	21
360P42	10"		Flat Steel	30
360PP42			Plastic	28

- Schedule 40 PVC well.
- Steel covers are 3/16" thick commercial grade steel with a zinc/ultraseal coating.
- Plastic covers are manufactured from High Density Polyethylene.
- Four 27" slots allow for ground electrode connections to be made before installation of test well.

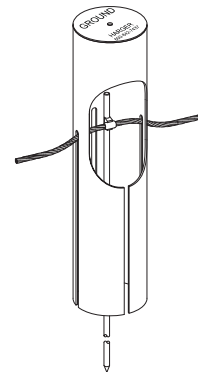

APPLICATION NOTES:

- Provides ready access to ground electrode for testing and inspection purposes.
- To prevent displacement by frost, the access well must be longer than the frost line is deep.

UL Listed Prefabricated Copper Ground Mesh

Harger prefabricated wire mesh can be supplied with no overhang, overlapping ends or butt splice ends.

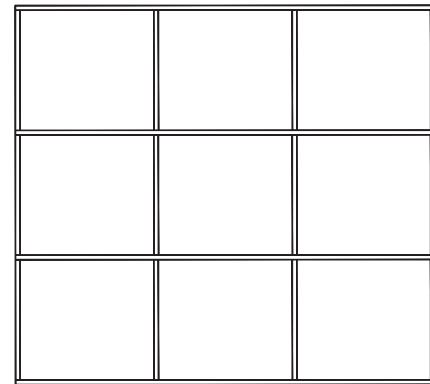

No Overhang

The overlapping end configuration is designed to allow for side by side connections of adjoining mats. This type of connection provides the easiest method of joining two mesh sections. Adding 2" to one half the conductor spacing provides the overlapping ends. For example, if the mesh size is 6" square, the overlapping end length is 5". See page 18 for CAPS mold connection.

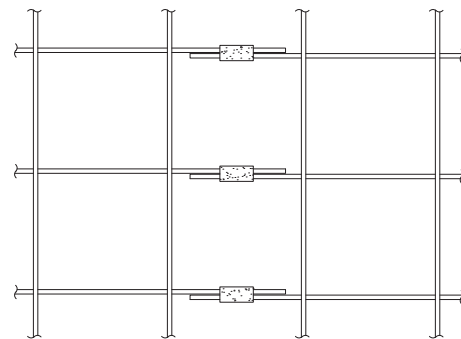

"Overlapping" ends

Mesh Net Weight in Pounds per Square Foot

Wire Type	Mesh Cell Size						
	4" x 4"	6" x 6"	8" x 8"	12" x 12"	24" x 24"	24" x 48"	48" x 48"
#10 Cu	0.199	0.132	0.099	0.067	0.034	0.027	0.019
8CW3D	0.257	0.171	0.129	0.087	0.045	0.035	0.024
#8 Cu	0.312	0.208	0.157	0.106	0.055	0.042	0.030
6CW3D	0.451	0.301	0.227	0.153	0.080	0.061	0.043
#6 Cu	0.491	0.328	0.248	0.167	0.087	0.067	0.047
#4 Cu	0.775	0.519	0.392	0.265	0.138	0.106	0.075

You need to first do the calculation for the net weight in order to calculate the gross shipping weight.

To Calculate Net Weight: Net Weight = Width (ft.) x Length (ft.) x Table Value (lb/ft²)

To Calculate Gross Shipping Weight: Gross Weight = Net Weight + [3.38 x (Mesh Width (ft.) + 1 (ft.))]

Example: 10' x 100', #6 Cu Wire Type, 6" x 6" Cell Size, from table 0.328 (lb/ft²)

Net Weight = 10 x 100 x 0.328 = 328 lbs.

Gross Weight = 328 + [3.38 x (10 + 1)] = 365 lbs.

Personnel Safety Mats

Harger personnel safety mats are designed to protect against "touch potentials" under fault conditions. Listed below are standard mat configurations, however mats can be customized by utilizing the personnel safety mat numbering system. The following example is a safety mat that is 6' wide x 6' long made up of #6 solid copper conductor. Conductors are spaced every 12" and the mat has a 1/0 AWG solid center wire.

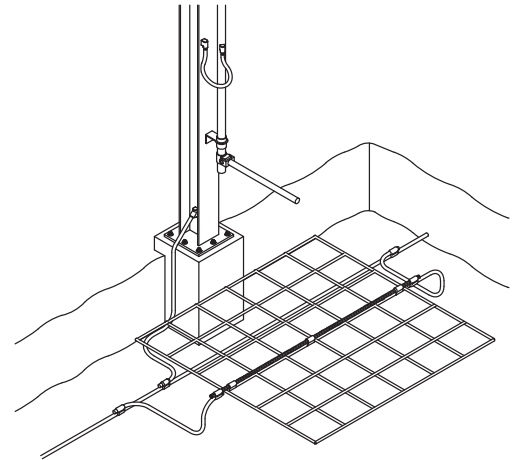
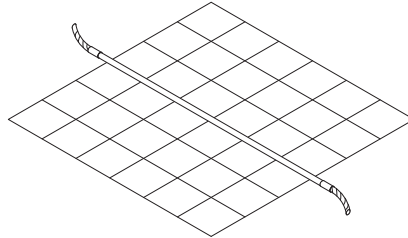

Personnel Safety Mat Numbering System

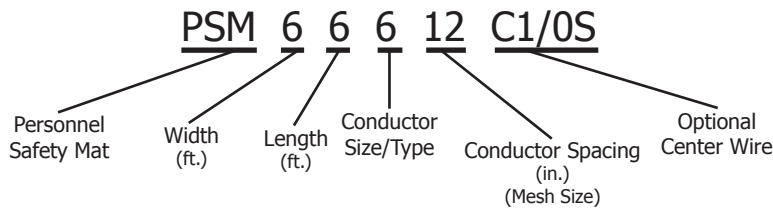

Standard Mat Configurations

- Mat Size: 4' x 4', 4' x 6', 6' x 6', 6' x 8'
- Wire Size: #4, #6, #8 AWG Solid Conductor
- Wire Type: Pure copper or copper clad steel (30% conductivity)
- Mesh Size: 2" square through 12" square in 2" increments
- Center Wire: Optional - See Page 28 for conductors available. Comes with standard 6" overhang on both sides of mat.

Conductors

Part No.	Type
4	Solid Copper
6	Solid Copper
6CW3D	Copper Clad 30% Conductivity
8	Solid Copper
8CW3D	Copper Clad 30% Conductivity

Standard Mat Sizes

Part No.	Width (ft.)	Length (ft.)	Conductor Size/Type (AWG)	Conductor Spacing (in.)	Optional Center Wire	Approx. Each Wt. (lbs.)
PSM4666C1/0S	4	6	6	6	1/0 Sol.	11
PSM4644C2/0	4	6	4	4	2/0	23
PSM61066C4/0S	6	10	6	6	4/0 Sol.	26

NOTES:

- 40% DSA conductor available. Please contact factory for more information.

One Hole Compression Lugs

Part No.	Conductor Size (AWG)	Hardware Size	Long Barrel	Color Code	Box Qty.	Approx. Box Wt. (lbs.)
GECL6	6	1/4	No	Blue	50	0.5
GECLB6	6	1/4	Yes	Blue	50	1
GECL63/8	6	3/8	No	Blue	50	1
GECLB63/8	6	3/8	Yes	Blue	50	3
GECL4	4	1/4	No	Gray	50	1
GECLB4	4	1/4	Yes	Gray	50	2
GECL2	2	5/16	No	Brown	50	2
GECLB2	2	5/16	Yes	Brown	50	3
GECL23/8	2	3/8	No	Brown	50	2
GECLB23/8	2	3/8	Yes	Brown	50	2
GECL21/4	2	1/4	No	Brown	50	2
GECLB21/4	2	1/4	Yes	Brown	50	2
GECL1/0	1/0	3/8	No	Pink	10	0.5
GECLB1/0	1/0	3/8	Yes	Pink	10	1
GECL2/0	2/0	3/8	No	Black	10	0.6
GECLB2/0	2/0	3/8	Yes	Black	10	2

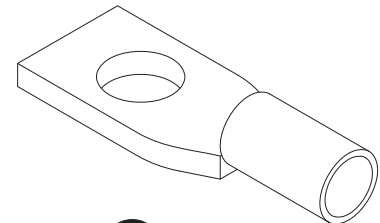

- Manufactured from electro plated tinned copper.
- For use on copper or tinned copper conductors.
- Lugs have inspection ports.
- Other sizes available. Please contact factory for more information.

Two Hole Long Barrel Compression Lugs

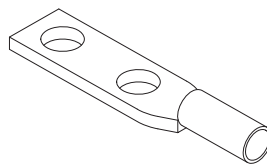

Part No.	Conductor Size (AWG)	O.C. Dim. B/T Holes	Hardware Size	Color Code	Box Qty.	Approx. Box Wt. (lbs.)
GECLB62B	6	.75"	3/8"	Blue	50	2
GECLB62C	6	1"	3/8"	Blue	50	2
GECLB42A	4	.625"	1/4"	Gray	25	2
GECLB42B	4	.75"	1/4"	Gray	25	2
GECLB42C	4	1"	3/8"	Gray	25	2
GECLB22A	2	.625"	1/4"	Brown	25	2
GECLB22B	2	.75"	3/8"	Brown	25	2
GECLB22BS	2 SOL	.75"	3/8"	White	25	2
GECLB22C	2	1"	3/8"	Brown	25	2
GECLB22CS	2 SOL	1"	3/8"	White	25	2
GECLB1/02C	1/0	1"	3/8"	Pink	10	0.8
GECLB1/02D	1/0	1.75"	1/2"	Pink	10	2
GECLB2/02C	2/0	1"	3/8"	Black	10	2
GECLB2/02D	2/0	1.75"	1/2"	Black	10	2

- Manufactured from electro plated tinned copper.
- For use on copper or tinned copper conductors.
- Lugs have inspection ports.
- Other sizes available. Please contact factory for more information.

Copper Offset Terminal Lugs

Part No.	Conductor Range (AWG)		Bolt Hole Size	Ampere Rating	Box Qty.	Approx. Box Wt. (lbs.)
	Maximum	Minimum				
GEOL1	10 Stranded	14 Stranded	#8	25	100	2
GEOL2	6 Stranded	14 Stranded	#8	50	100	2
GEOL3	2 Stranded	8 Stranded	1/4"	70	100	4
GEOL4	1/0 Stranded	8 Stranded	1/4"	125	25	3
GEOL5	4/0 Stranded	2 Stranded	3/8"	225	25	6
GEOL500MCM	500 MCM	1/0 Stranded	1/2"	400	10	8

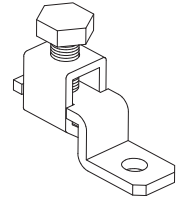

Listed 467

Copper Split Bolts

Part No.	Conductor Range for Equal Main (AWG)	Minimum Tap	Box Qty.	Approx. Box Wt. (lbs.)
GESB6	6 Sol. - 8 Sol.	16 SOL	100	6
GESB2	2 Str. - 6 Sol.	14 SOL	50	6
GESB1/0	1/0 Str. - 4 Sol.		20	4
GESB2/0	2/0 Str. - 2 Sol.		15	4
GESB4/0	4/0 Str. - 1/0 Sol.	10 SOL	10	4
GESB250	250 MCM - 1/0 Str.		10	4

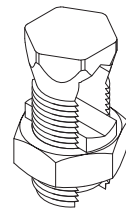

Listed 467

- Suitable for direct burial.

Ground Rod Clamps

Part No.	Ground Rod Size	Conductor Range (AWG)	Box Qty.	Approx. Box Wt. (lbs.)	UL Mark
300LD	1/2"	10 Sol. - #2 Str.	10	5	Yes
301LD	5/8"			1	
302LD	3/4"			2	
303LD	1"	8 Sol. - 4/0		6	

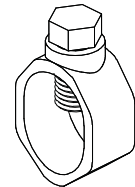

Listed 467

- Light duty ground rod clamp.
- Bronze cap screw secures the cable to the ground electrode.
- Commonly called acorn or tear drop clamp.

Universal Ground Rod Clamp - Light Duty

Part No.	Ground Rod Size	Conductor Range (AWG)	Box Qty.	Approx. Box Wt. (lbs.)	UL Mark
302UGRC	3/8"	1/0 - 10 SOL	10	2	No
	1/2"				Yes
	5/8"				
	3/4"	1/0 - 8 SOL			

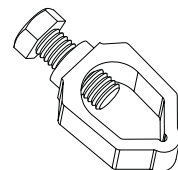

Listed 467

- Light duty ground rod clamp for securing cable to ground rod.
- Eliminates the need to inventory assorted different-size clamps.
- Replaces a wide range of products made for economy, standard duty, heavy duty and extra heavy duty applications.
- Made from corrosion resistant silicon bronze.
- Accommodates 3/8" to 3/4" ground rods and #10 Solid to 1/0 Stranded conductor.
- Tested to 300 inch-pounds.
- UL and CSA listed for Direct Burial.

NOTES:

- Other sizes available. Please contact factory for more information.

Mechanical Compression Tools

Grounding Components



Part No.	Length	Approx. Each Wt. (lbs.)
MCT	24"	6

- Dieless adjustable compression tool with steel handle.
- Works with copper conductor sizes #8 AWG through 250 MCM and aluminum conductors #8 AWG through 4/0.
- For use with compression lugs and light duty compression taps.
- Approximately 2 tons of force.

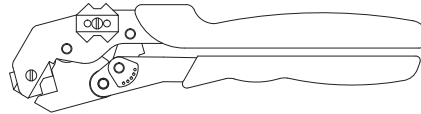

Part No.	Length	Approx. Each Wt. (lbs.)
MCT81/0	11"	2

- Handy compression tool terminates copper compression connectors in wire sizes #8 AWG through 1/0.
- Handle length facilitates two-handed crimps when necessary.
- Approximately 2 tons of force.
- Dies included.

C-Type Compression Taps

Heavy Duty C-Taps

Part No.	Conductor (AWG)		Die Index	Box Qty.	Approx. Box Wt. (lbs.)
	Run	Tap			
CT4666	#4 Stranded #6 Solid	#6 Stranded #6 Solid	BG	50	2
CT4446		#4 Stranded #4 Solid		50	2
CT2248	#2 Stranded #2 Solid	#4 Stranded #8 Solid	C	50	4
CT2222		#2 Stranded #2 Solid		50	4
CT22/0	2/0 Stranded 1/0 Solid	#2 Stranded #8 Solid	O	10	2
CT24/0	4/0 Stranded 3/0 Solid	#2 Stranded #6 Solid	D3	10	4
CT2/02/0	2/0 Stranded 1/0 Solid	2/0 Stranded 1/0 Solid	O	10	2
CT4/02/0				4/0 Stranded 3/0 Solid	D3
CT4/04/0	4/0 Stranded 3/0 Solid	4/0 Stranded 3/0 Solid	D3		

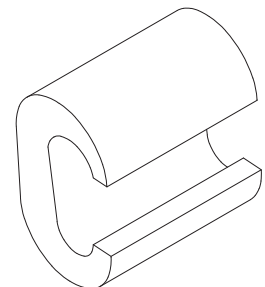

Megger Ground Testing Equipment

High Sensitivity Ground Resistance Tester

Part No.	Range Resistance	Power Source	Display	Approx. Each Wt. (lbs.)
DET2/2	0.010 Ω - 19.99 kΩ	Rechargeable Battery	Digital	5

- The DET2/2 is ideal for testing complex systems such as encountered in larger substations or telecommunications grounding systems.



4 Terminal Ground Resistance Testers

Part No.	Power Source	Approx. Each Wt. (lbs.)
DET4TR2	Rechargeable battery	5

- Four Terminal Tester
- Please contact factory for additional details.



Part No.	Power Source	Approx. Each Wt. (lbs.)
DET4TD2	Dry cell battery	5

- Four Terminal Tester
- Please contact factory for additional details.



Megger Earth/Ground Resistance & Leakage Current Clamp Testers

Part No.	Description	Approx. Each Wt. (lbs.)
DET14C	Clamp-On Ground Resistance Tester	2
DET24C		

- The Megger models DET14C and DET24C measure earth/ground resistance and current flow using clamp-on technology.



Harger Ground Test Kits

Accessory test kits are designed for doing three point measurements on larger sites.

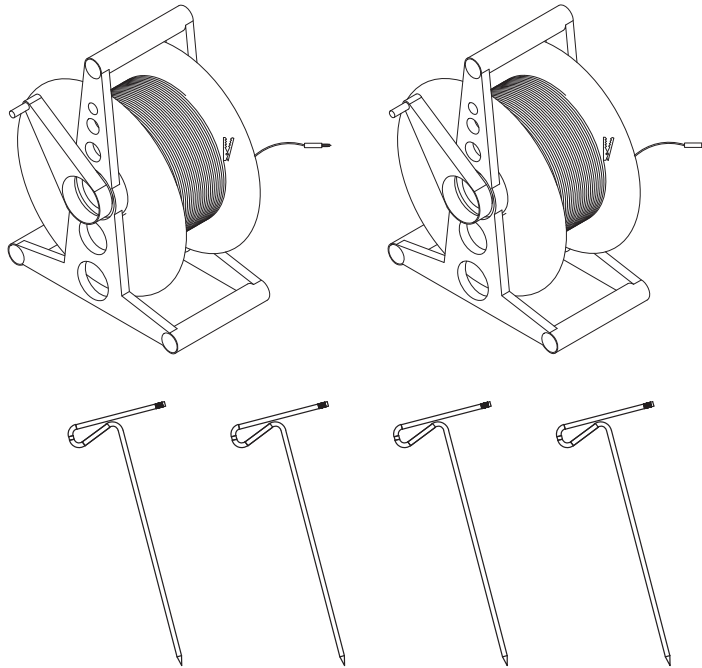

Part No.	Description	Qty.	Approx. Each Wt. (lbs.)
GTKIT300	Test Kit with 300' long test leads & 12 spikes	EACH	20
GTKIT500	Test Kit with 500' long test leads & 12 spikes	EACH	25

GTKIT Includes:

- (2) 300' or 500' long test lead reels. Durable reel with leads made from #18 AWG (65/36) test lead wire.
- (12) Test spikes. Spikes are 24" long and made of steel with a dipped zinc ultra-seal finish.

Part No.	Description	Qty.	Approx. Each Wt. (lbs.)
GRDTESTPIN	24" Ground Test Spike	EACH	1

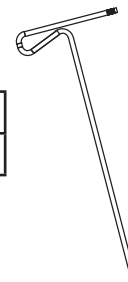

Part Number Index

<u>Part Number</u>	<u>Page No.</u>	<u>Part Number</u>	<u>Page No.</u>	<u>Part Number</u>	<u>Page No.</u>
1/0-19	29	ADPSLV2B	25	CAGD344SM	19
1/019G	29	ADPSLV4	25	CAGD346L	19
2	28	ADPSLV4/0	22	CAGD346SL	19
2/0-7	29	ADPSLV4/0	22	CAGD581/0M	19
2/0-19	29	ADPSLV4/0	22	CAGD581M	19
2-7	29	ADPSLV6	25	CAGD582/0M	19
2-19G	29	CABS1/01/0M	17	CAGD582M	19
2/019G	29	CABS2/02/0M	17	CAGD582SM	19
2T	28	CABS2S2SL	17	CAGD584L	19
4	28	CABS4S4SL	17	CAGD584SL	19
4-7	29	CABS6S6SL	17	CAGD586L	19
4-19G	29	CABS8S8SL	17	CAGD586SL	19
4T	28	CABS10S10SL	17	CAHD1/0A	10
6	28	CABS11L	17	CAHD1/0H2.5X3.5A	10
6-7	29	CABS12S12SL	17	CAHD1/0H4X8A	10
6-19G	29	CABS22L	17	CAHD1/0H10X18A	10
6T	28	CABS44L	17	CAHD1A	10
8	28	CABS66L	17	CAHD1H4X8A	10
8-7	29	CACIHD2A	14	CAHD1H10X14A	10
8T	28	CACIHD2SA	14	CAHD2/0A	10
10	28	CACIHD4A	14	CAHD2/0H2.5X3.5A	10
27G	29	CACIHD4SA	14	CAHD2/0H4X8A	10
47G	29	CACIHD6A	14	CAHD2/0H10X18A	10
67G	29	CACIHD6SA	14	CAHD2A	10
110	30	CACIHDB2A	23	CAHD2H1X3.5A	10
126G	30	CACIHDB2H**A	23	CAHD2H4X8A	10
126GUPC	30	CACIHDB4A	23	CAHD2H10X14A	10
128G	30	CACIHDB4H**A	23	CAHD2SA	10
128GUPC	30	CACIHDFB1/0A	22	CAHD2SH1X3.5A	10
300LD	37	CACIHDFB1/0H**A	22	CAHD2SH4X8A	10
301LD	37	CACIHDFB1A	22	CAHD4A	10
302LD	37	CACIHDFB1H**A	22	CAHD4H4X5A	10
302UGRC	37	CACIHDFB2/0A	22	CAHD4H.75X3.5A	10
303LD	37	CACIHDFB2/0H**A	22	CAHD4SA	10
348	30	CACIHDFB2A	22	CAHD4SH4X5A	10
348G	30	CACIHDFB2H**A	22	CAHD4SH.75X3.5A	10
358P42	33	CACIHDFB4A	22	CAHD6A	10
358PP	33	CACIHDFB4H**A	22	CAHD6H.75X3.5A	10
358PP42	33	CACIHT2A	14	CAHD6SA	10
358PS	33	CACIHT2SA	14	CAHD6SH.75X3.5A	10
360P42	33	CACIHT4A	14	CAHDB2A	23
360PP	33	CACIHT4SA	14	CAHDB2H4A	23
360PP42	33	CACIHT6A	14	CAHDB2H4A	23
360PS	33	CACIHT6SA	14	CAHDB2H6X8A	23
362PS	33	CACIVA2M	15	CAHDB2H6X8A	23
588	30	CACIVA2SM	15	CAHDB4A	23
588G	30	CACIVA4L	15	CAHDFB1/0A	22
588GUPC	30	CACIVA4SL	15	CAHDFB1/0H4A	22
588RUS	30	CACIVA6L	15	CAHDFB1/0H6X8A	22
588UPC	30	CACIVA6SL	15	CAHDFB1A	22
1208UPC	30	CAGD12F1/0M	19	CAHDFB1H4A	22
1210	30	CAGD12F1M	19	CAHDFB1H6X8A	22
3410	30	CAGD12F2/0M	19	CAHDFB2/0A	22
3410G	30	CAGD12F2L	19	CAHDFB2/0H4A	22
3412	30	CAGD12F2SL	19	CAHDFB2/0H6X8A	22
5810	30	CAGD12F4L	19	CAHDFB2A	22
5810G	30	CAGD12F4SL	19	CAHDFB2H4A	22
5810GUPC	30	CAGD12F6L	19	CAHDFB2H6X8A	22
5810UPC	30	CAGD12F6SL	19	CAHDFB4A	22
ADPSLV1	22	CAGD341/0M	19	CAHDFB4H4A	22
ADPSLV1	25	CAGD341M	19	CAHDFB4H6X8A	22
ADPSLV1/0	25	CAGD342/0M	19	CAHT1/0A	11
ADPSLV2/0	25	CAGD342M	19	CAHT1/0H3X4A	11
ADPSLV2A	25	CAGD342SM	19	CAHT1/0H5X6A	11
ADPSLV2B	22	CAGD344M	19	CAHT1/0H8X10A	11

<u>Part Number</u>	<u>Page No.</u>	<u>Part Number</u>	<u>Page No.</u>	<u>Part Number</u>	<u>Page No.</u>
CAHT1/0H12X28A	11	CAPB28L	17	CAVA2/0V12X16M	12
CAHT1A	11	CAPB28SL	17	CAVA2L	12
CAHT1H2X3.5A	11	CAPB44L	17	CAVA2SL	12
CAHT1H4X8A	11	CAPB46L	17	CAVA2SV1X1.5L	12
CAHT1H10X16A	11	CAPB46SL	17	CAVA2SV2X4L	12
CAHT2/0A	11	CAPB48L	17	CAVA2SV5X12L	12
CAHT2/0H3X4A	11	CAPB48SL	17	CAVA2V1X1.5L	12
CAHT2/0H5X6A	11	CAPB66L	17	CAVA2V2X3L	12
CAHT2/0H8X10A	11	CAPB66SL	17	CAVA2V4X6L	12
CAHT2/0H12X28A	11	CAPB68L	17	CAVA2V8X12L	12
CAHT2A	11	CAPB68SL	17	CAVA4L	12
CAHT2H2X3.5A	11	CAPT1/01/0SM	18	CAVA4SL	12
CAHT2H4X8A	11	CAPT1/02M	18	CAVA4SV2X4L	12
CAHT2H10X16A	11	CAPT1/02SM	18	CAVA4SV5X10L	12
CAHT2SA	11	CAPT1/04M	18	CAVA4SV.75X1.5L	12
CAHT2SH2X3.5A	11	CAPT1/06M	18	CAVA4V2X4L	12
CAHT2SH4X6A	11	CAPT1/06SM	18	CAVA4V5X10L	12
CAHT2SH8X10A	11	CAPT1/08M	18	CAVA4V.75X1.5L	12
CAHT4A	11	CAPT1/08SM	18	CAVA6L	12
CAHT4H2.5X5A	11	CAPT2/01/0M	18	CAVA6SL	12
CAHT4H6X10A	11	CAPT2/02/0M	18	CAVA6SV4X10L	12
CAHT4H.75X2A	11	CAPT2/02M	18	CAVA6SV.75X3.5L	12
CAHT4SA	11	CAPT2/02SM	18	CAVA6V4X10L	12
CAHT4SH2.5X5A	11	CAPT2/04M	18	CAVA6V.75X3.5L	12
CAHT4SH.75X2A	11	CAPT2/06M	18	CAVDO2A	13
CAHT4SHX10A	11	CAPT2/06SM	18	CAVDO2SA	13
CAHT6A	11	CAPT2/08M	18	CAVDO2SV1X3.5A	13
CAHT6H2.5X5A	11	CAPT2/08SM	18	CAVDO2SV4X12A	13
CAHT6H6X10A	11	CAPT2S2SM	18	CAVDO2V1X3.5A	13
CAHT6H.75X2A	11	CAPT22M	18	CAVDO2V4X12A	13
CAHT6SA	11	CAPT22SM	18	CAVDO4A	13
CAHT6SH2.5X5A	11	CAPT24M	18	CAVDO4SA	13
CAHT6SH6X10A	11	CAPT26M	18	CAVDO4SV4X12A	13
CAHT6SH.75X2A	11	CAPT26SM	18	CAVDO4SV.75X3.5A	13
CAJB2X18	23	CAPT28M	18	CAVDO4V4X12A	13
CAJB2X24	23	CAPT28SM	18	CAVDO4V.75X3.5A	13
CAJB4X18	23	CAPT44L	18	CAVDO6A	13
CAJB4X24	23	CAPT46L	18	CAVDO6SA	13
CALE1/011612M	21	CAPT46SL	18	CAVDO6SV4X12A	13
CALE2/0181M	21	CAPT48L	18	CAVDO6SV.75X3.5A	13
CALE2S11612L	21	CAPT48SL	18	CAVDO6V4X12A	13
CALE4S11612L	21	CAPT66L	18	CAVDO6V.75X3.5A	13
CALE6S11612L	21	CART1/02N	16	CGS	26
CALE111612L	21	CART1/02SN	16	CSKITHPA	27
CALE211612L	21	CART1/04N	16	CSKITHPH3	27
CALE411612L	21	CART1/06N	16	CSKITVPA	27
CALE611612L	21	CART2/02N	16	CSKITVPH3	27
CAPB1/02M	17	CART2/02SN	16	CT2/02/0	38
CAPB1/04M	17	CART2/04N	16	CT4/02/0	38
CAPB1/06M	17	CART2/06N	16	CT4/04/0	38
CAPB1/06SM	17	CART2S2SN	16	CT22/0	38
CAPB1/08M	17	CART22N	16	CT24/0	38
CAPB1/08SM	17	CART22SN	16	CT2222	38
CAPB2/02N	17	CART24N	16	CT2248	38
CAPB2/04M	17	CART26N	16	CT4446	38
CAPB2/06M	17	CART44N	16	CT4666	38
CAPB2/06SM	17	CART66N	16	DET2/2	39
CAPB2/08M	17	CAVA1/0M	12	DET4TD2	39
CAPB2/08SM	17	CAVA1/0V2.5X4M	12	DET4TR2	39
CAPB12M	17	CAVA1/0V5X10M	12	DET14C	39
CAPB14M	17	CAVA1/0V12X16M	12	DET24C	39
CAPB16M	17	CAVA1M	12	DISK15/65	26
CAPB16SM	17	CAVA1V1.5X2.5M	12	FLTIG	26
CAPB18M	17	CAVA1V3X4M	12	FLTIGEXT	26
CAPB18SM	17	CAVA1V5X10M	12	G1134F1/0NU	20
CAPB22M	17	CAVA1V12X16M	12	G1134F2/0NU	20
CAPB24M	17	CAVA2/0M	12	G1134F2NU	20
CAPB26L	17	CAVA2/0V3X4M	12	G1134F4NU	20
CAPB26SL	17	CAVA2/0V5X10M	12	G1134F8NU	20

<u>Part Number</u>	<u>Page No.</u>	<u>Part Number</u>	<u>Page No.</u>	<u>Part Number</u>	<u>Page No.</u>
G1158F1/ONU	20	GECL21/4	36	TRCHD	25
G1158F2/ONU	20	GECL23/8	36	UMMHDA	27
G1158F2NU	20	GECL63/8	36	WRPSLV	25
G1158F4NU	20	GECLB1/0	36		
G1158F8NU	20	GECLB1/02C	36		
G2134F1/ONU	20	GECLB1/02D	36		
G2134F2NU	20	GECLB2	36		
G2134F4NU	20	GECLB2/0	36		
G2134F8NU	20	GECLB2/02C	36		
G2158F2NU	20	GECLB2/02D	36		
G2158F4NU	20	GECLB4	36		
G2158F8NU	20	GECLB6	36		
G3134F1/ONU*	20	GECLB21/4	36		
G3134F2NU	20	GECLB22A	36		
G3134F4NU	20	GECLB22B	36		
G3134F8NU	20	GECLB22BS	36		
G3158F1/ONU	20	GECLB22C	36		
G3158F1/ONU*	20	GECLB22CS	36		
G3158F2NU	20	GECLB23/8	36		
G3158F4NU	20	GECLB42A	36		
G3158F8NU	20	GECLB42B	36		
G4134F2NU	20	GECLB42C	36		
G4134F4NU	20	GECLB62B	36		
G4134F8NU	20	GECLB62C	36		
G4158F2NU	20	GECLB63/8	36		
G4158F4NU	20	GEOL1	37		
G4158F8NU	20	GEOL2	37		
G11341/ONU	20	GEOL3	37		
G11342/ONU	20	GEOL4	37		
G11342NU	20	GEOL5	37		
G11344NU	20	GEOL500MCM	37		
G11348NU	20	GESB1/0	37		
G11581/ONU	20	GESB2	37		
G11582/ONU	20	GESB2/0	37		
G11582NU	20	GESB4/0	37		
G11584NU	20	GESB6	37		
G11588NU	20	GESB250	37		
G21341/ONU	20	GRD34I	30		
G21342NU	20	GRD58	30		
G21344NU	20	GRDTESTPIN	40		
G21348NU	20	GTKIT300	40		
G21581/ONU	20	GTKIT500	40		
G21582NU	20	MCT	38		
G21584NU	20	MCT81/0	38		
G21588NU	20	MH3	27		
G31341/ONU	20	MH4	27		
G31342NU	20	MLDSLR	26		
G31344NU	20	OXL181	21		
G31348NU	20	OXL1812B	21		
G31581/ONU	20	OXL11612	21		
G31582NU	20	OXL116122A	21		
G31584NU	20	PSM4644C2/0	35		
G31588NU	20	PSM4666C1/OS	35		
G41342NU	20	PSM61066C4/OS	35		
G41344NU	20	RASP	26		
G41348NU	20	RPLFLT	26		
G41582NU	20	SB3A9.5	23		
G41584NU	20	SB4L20	23		
G41588NU	20	SB4L22	23		
GAW910	33	SB4S17	23		
GAW121212HD	32	SB4S19	23		
GAW121218HD	32	SB5L20	23		
GAW121224HD	32	SB5L22	23		
GAW132418HD	32	SB5S17	23		
GECL1/0	36	SB5S19	23		
GECL2	36	SXL181	21		
GECL2/0	36	SXL1812B	21		
GECL4	36	SXL11612	21		
GECL6	36	SXL116122A	21		

Key Word Index

4 Terminal Ground Resistance Testers.....	39	CAHD	10
Adapter Sleeves	25	CAHDFB	22
Chain Support Handle Clamps	27	CAHT	11
Clamps.....	37	CALE	21
Cold Galvanizing Spray	26	CAPB.....	17
Conductor Identification.....	7	CAPS.....	18
Connection Types.....	9	CAPT.....	18
Copper Clad Steel Ground Rod	30	CART.....	16
Copper Jumper Bonds	23	CAVA.....	12
Copper Offset Terminal Lugs	37	CAVDO	13
Copper Split Bolts.....	37	Uni-Shots.....	20
Copper Strap Bonds.....	23	Mold Sealer.....	26
C-Type Compression Taps.....	38	NUWTube Welding Process	5
Exothermic Process	4	One Hole Compression Lugs.....	36
Flint Igniter.....	26	Personnel Safety Mats	35
Galvanized Steel Ground Rod	30	PVC Slotted Well with Cover	33
Green Insulated Conductor	29	PVC Well with Cover	33
Ground Access Wells	32	Rasp	26
HDPE Well with Cover.....	33	Solid Copper Conductor	28
Light Weight Polymer Concrete.....	32	Solid Tinned Copper Conductor	28
PVC Slotted Well with Cover	33	Steel Pipe Sizes.....	8
PVC Well with Cover	33	Stranded Copper Conductor	29
Ground Rod Clamps.....	37	Two Hole Long Barrel Compression Lugs.....	36
Ground Rod Driver	30	UL Listed Prefabricated Copper Ground Mesh	34
Ground Rods.....	8	Ultrafill - Earth (Ground) Enhancement Material.....	31
Ground Testing Equipment.....	39-40	Uni-Shots.....	20
Hammer Dies.....	22	Universal Ground Rod Clamp.....	37
Harger Ground Test Kits.....	40	Wrap Sleeves	25
HDPE Well with Cover.....	33		
Heavy Duty C-Taps	38		
High Sensitivity Ground Resistance Tester	39		
Lugs.....	36-37		
Magnetic Hold Down For 'A' Molds	27		
Mechanical Compression Tools	38		
Megger Earth/Ground Resistance & Leakage Current Clamp Testers	39		
Megger Ground Testing Equipment.....	39		
Mold Accessories			
Torch Head	25		
Mold Care & Use	26		
Disks.....	26		
Mold Fastening & Mounting.....	27		
Mold Handle Clamp	27		
Mold Numbering System	6		
MOLDS			
CABS.....	17		
CACIHD	14		
CACIHDFB	22		
CACIHT	14		
CACIVA.....	15		
CACIVDO.....	15		
CAGD	19		
CAGO	19		

HARGER®



ULTRAWELD®



Harger Lightning & Grounding
301 Ziegler Drive, Grayslake, IL 60030
800.842.7437 | 847.548.8700 | Fax: 847.548.8755
Email: hargersales@harger.com | Website: www.harger.com

