

Rail Equipment Catalog

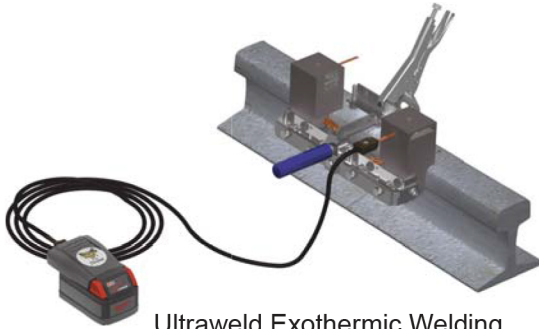

Ultraweld Exothermic Welding



Signal & Power Bonds

Grounding Products
Tower Mounting Hardware
Coax & Specialty Grounding



Harger Lightning & Grounding

Rail Products Catalog

Since its beginning in 1960, Harger Lightning & Grounding has become a leader in the grounding and lightning protection industries. Founded on the principles of honesty, integrity and technical expertise, Harger has been able to provide grounding solutions and lightning protection equipment for many satisfied customers.

Harger Lightning & Grounding has built its reputation on providing a broad line of quality products at a competitive price, coupled with extraordinary service.

We have experience in all facets of these markets including product manufacturing and installation. We have the staff and facilities to handle your special requirements. Our complete engineering and manufacturing facilities have the capacity to produce special items as well as modify our standard component line. Let us know the application and we can provide the necessary equipment.

In order to meet the rigorous demands of our markets, Harger maintains an extensive inventory to ensure prompt deliveries to our customers, domestically and worldwide. Headquartered near Chicago, Illinois, Harger is centrally located to serve the needs of customers from coast to coast.

**Information changes after the catalog is printed.
For the most up to date information,
please go to our website at
www.harger.com**

Table of Contents

Introduction	
Exothermic Process	7
UltraShot® Drop-In Process	8
NUWTube® Pour & Shoot Process.....	9
Connection Types	10
Mold Numbering System.....	11
Signal Bonds (Welded)	
3/16" Joint Head Bonds, Welders & Molds	12
3/16" XS Style Bonds.....	12
3/16" Tab Style Bonds	12
5/16" Joint Head Bonds, Welders & Molds	13
5/16" Tab Style Bonds	13
Single Rail Head Welders	13
Track Circuit Connectors (Web)	14
Mechanical Compression Tools	14
3/16" Diameter Track Connectors	14
1" x 3/16" Web Welder	14
Jumper, Bootleg & Switch Bonds (Web)	15
Field Made Tab Style Bonds	16
Bond Strand Signal Cable.....	16
Propulsion Rail Head Bonds (C-Type)	17
Propulsion Web Bonds (W-Type)	
Propulsion Web Bonds (W-Type)	18
Stub End Bonds.....	18
Stub End Bonds (Bare & Insulated).....	18
Joint/Cross Bonds.....	19
Joint/Cross Bonds (Bare & Insulated).....	19
Web Grounding Connections	
Web Grounding Connections	20
RMVH	20
Web Grounding Connections	21
RMVL	21
RMVR.....	21
Conductor Specifications	
Conductor Specifications (C-Type Bonds)	22
Conductor Specifications for Copper Ropelay	22
Conductor Specifications for Copper Concentric Strand	22
Signal Hut Grounding	
Aluminum to Copper Ground Studs	24
Steel Signal Case Ground Plates	24
Feedthrough Stud	24
Ultraweld Connections	
BS	25
PB	25
PS	25
RT	26
PT	26
GD.....	27
GO.....	27
Uni-Shots - UltraShot®	28
Uni-Shots - NUWTube®	29
HB.....	30

Table of Contents

HD.....	30
VA.....	31
VD.....	31
VT.....	32
VH.....	32
VR.....	33
VL.....	33
LBJ.....	34
Tinned Copper Lugs - Bent J.....	34
LE.....	34
Tinned Copper Lugs - Straight & Offset.....	35
Materials, Tools, & Accessories	
Weld Metal.....	36
NUWTube®.....	36
UltraShot®.....	36
Ultraweld® Molds.....	36
Low Smoke-No Flame System.....	37
Low Smoke-No Flame Adapter Clamp.....	37
Low Smoke-No Flame Kits.....	37
Low Smoke-No Flame Filters.....	37
Replacement Filter Housing.....	37
UltraShot Drone.....	38
Drone Accessories.....	38
Battery.....	38
Charger.....	38
6' Cord.....	38
Drone.....	38
Drone Accessory Kit.....	38
Pouch.....	38
Case.....	38
Mold Accessories.....	39
Wrap Sleeves.....	39
Flint Igniter.....	39
Adapter Sleeves.....	39
Torch Head.....	39
Adapting Molds to Fit Conductors.....	39
Ceramic Rebar Packing Material.....	40
Mold Sealer.....	40
Cable & Work Surface Preparation.....	40
Cable Cleaning Brush - Heavy Duty.....	40
Cold Galvanizing Spray.....	40
Cable Cleaning Brush.....	40
Rasp.....	40
Mold Care & Use.....	41
Mold Blanket.....	41
Mold Cleaning Brushes.....	41
Mold Cleaning Spades.....	41
Disk Kit.....	41
Disks.....	41
Mold Fastening & Mounting.....	42
Mold Handle Clamp.....	42
Magnetic Support Handle Clamp.....	42
Magnetic Support Kit.....	42

Table of Contents

Chain Support Handle Clamp.....	42
Chain Support Kits.....	42
Hold Down Kit.....	43
Mold Stabilizer Kit.....	43
Technical Information	
Conductor Identification	44
Copper-Clad Steel Conductors	45
Ground Rods	45
Grounding Components	
Green Insulated Conductor	46
Stranded Copper Conductor	46
Concentric Lay Soft-Drawn Bare Copper.....	46
Solid Copper Conductor	47
Solid Tinned Copper Conductor	47
Copper Clad Steel Ground Rod	48
Stainless Steel Ground Rod	48
Galvanized Steel Ground Rod	48
Ground Rod Drivers	49
Drive Sleeves	49
Drive Studs	49
Ground Rod Driver	49
Flexible Gate Jumpers	50
Universal Pipe Clamps	51
One Hole, Standard Barrel, Compression Lugs	52
One Hole, Long Barrel, Compression Lugs	52
Two Hole, Long Barrel, Compression Lugs	53
Two Hole, Slotted, Long Barrel, Compression Lugs	54
Long Barrel Butt Splices	54
C-Type Compression Taps	54
Heavy Duty C-Taps.....	54
Mechanical Compression Tools	55
CPC & APC Pipe Clamps	56
Pipe Range .5/.75.....	56
Pipe Range 1/1.25.....	56
Pipe Range 1.5/2 - 5/6.....	56
Ground Bar Hole Patterns	57
GBI Ground Bars	57
"P" Pattern.....	57
"J" Pattern.....	58
"M" Pattern.....	58
Mounting Brackets	59
Insulated Tower Standoff for Round Members	59
TSOINS Series	59
Wall Mount.....	59
Insulated Tower Standoffs with Hose Clamp.....	59
Stainless Steel Angle Adapters.....	59
Universal Ground Rod Clamp - Light Duty	60
Copper Offset Terminal Lugs	60
Copper Split Bolts	60
Ground Rod Clamps	60
Ultrafill - Earth (Ground) Enhancement Material	61

Table of Contents

Ground Access Wells	62
Light Weight Polymer Concrete.....	62
PVC Slotted Well with Cover	63
PVC Well with Cover	63
HDPE Well with Cover.....	63
UL Listed Prefabricated Copper Ground Mesh	64
Personnel Safety Mats	65
Part Number Index	67
Key Word Index	72

Exothermic Process

The Exothermic Process is an effective and safe method of welding copper to copper, copper to cast iron or copper to steel for the purpose of producing permanent electrical connections. Exothermically welded connections are produced from the energy and molten copper metal liberated from an exothermic reaction between powdered copper oxide and aluminum. The exothermic reaction takes place at a theoretical temperature of 4600°F and as a result, molten copper alloy is created and used to melt the conductors and cast the finished connection. The exothermic reaction takes place in a semi-permanent graphite mold that will last 50 or more welds if properly cared for. The process is simple and easy to implement providing an on-site means to make welded electrical connections without requiring external power, equipment or the special training usually required for brazing and welding. The process will provide a finished connection that will always provide an ampacity that exceeds the conductors they join and will never loosen.



UltraShot® Drop-In Process

Exothermic Process



Step 1:

- Clean and dry conductors and mold
- Insert conductors into mold



Step 2:

- Close handle clamp and lock mold
- Insert UltraShot drop-in into mold

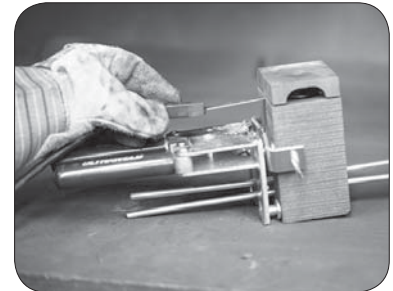

Step 3:

- Attach cord to UltraShot igniter



Step 4:

- Push and hold both igniter buttons at the same time

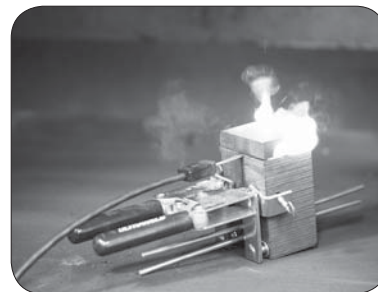

Step 5:

- Reaction is made
- Open mold and remove connection
- Remove slag and clean mold before making the next connection

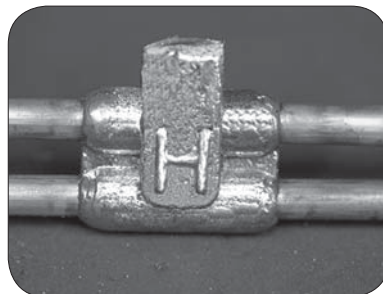

A completed UltraShot connection

Note: When exothermic welding, always wear proper clothing, safety glasses and gloves. Harger offers UltraShot training. Please contact the factory for more information.

NUWTube® Pour & Shoot Process

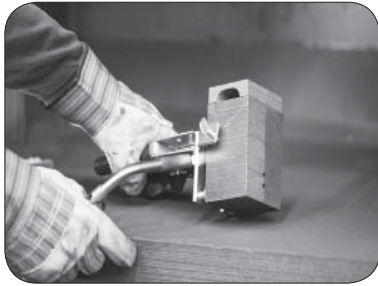

Step 1:

- Torch dry the mold before making the first connection



Step 2:

- Clean and dry conductors
- Insert conductor into mold
- Close handle clamp and lock mold

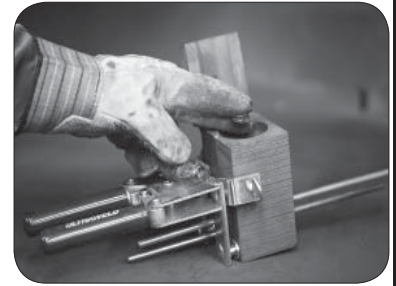

Step 3:

- Insert disk into mold



Step 4:

- Remove Clear plastic cap from NUWTube
- Pour weld metal into mold



Step 5:

- Close Lid
- Remove orange cap from starting powder chamber
- Sprinkle next to ignition hole



Step 6:

- Ignite material located on top of the lid using a flint igniter (FLTIG)



Step 7:



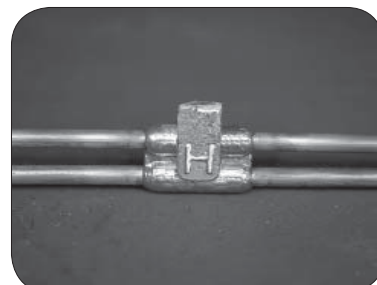





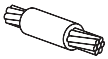

- After the connection is complete, open the mold and remove the connection
- Remove slag and clean mold before making the next connection







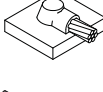
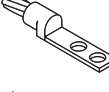
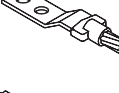
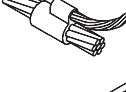
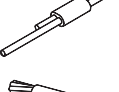
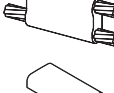





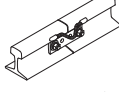
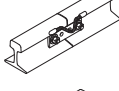

Complete NUWTUBE connection

Note: When exothermic welding, always wear proper clothing, safety glasses and gloves. Harger offers Ultraweld training. Please contact the factory for more information.

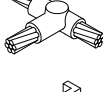
Connection Types

Connection Type	Page	Catalog Item
 BS	25	Yes
 G11	28,29	Yes
 G21	28,29	Yes
 G31	28,29	Yes
 G41	28,29	Yes
 GD	27	Yes
 GO	27	Yes
 HB	30	Yes
 HD	30	Yes
 LBJ	34	Yes
 LE	34	Yes
 PB	25	Yes
 PS	25	Yes
 PT	26	Yes
 RMFPL		No
 RMFPLB		No

Connection Type	Page	Catalog Item
 RMFPR		No
 RMFPRB		No
 RMFPT		No
 RMJH		No
 RMJHC		No
 RMLF		No
 RMVH	20	Yes
 RMVRL	21	Yes
 RMVR	21	Yes
 RMW	15	Yes
 RT	26	Yes
 VA	31	Yes
 VD	31	Yes
 VH	32	Yes
 VT	32	Yes

For more exothermic connections, please see our Master Catalog.

Mold Numbering System

The Part Number gives, in code, the complete information of the mold.

- Type of connection, conductor size(s) and mold price key.
- If frame or handle clamp is not required, add a suffix "X" after the mold part number.
- See charts on page 44 for conductor code references.
- For mold Wear Plates, add suffix "WP" to the end of the Mold Part No.
- For molds using solid conductor, add suffix "S" after conductor number. Example RT2S2SB for a #2 Solid Run and Tap mold.
- The below number are examples only. For actual part numbers, please refer to the proper pages in this catalog or request a part number from Harger Customer Service.
- If there is a "H" or a "V" after the primary conductor then the secondary conductor is a pipe in a horizontal or vertical orientation, respectively.

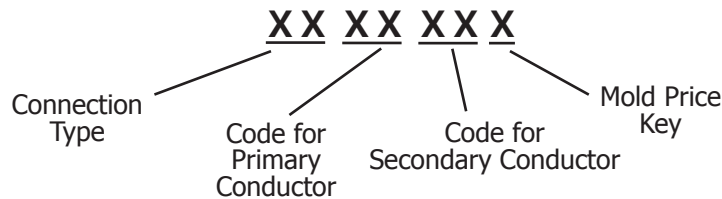

Examples

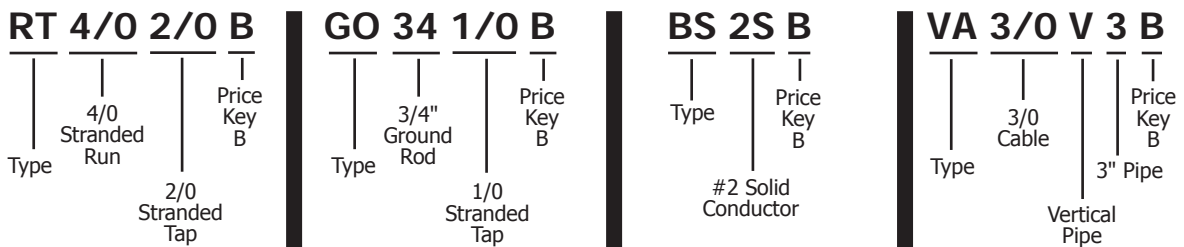

3/16" Joint Head Bonds, Welders & Molds

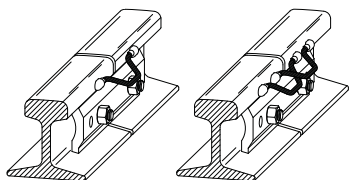

Joint Head Signal Bonds

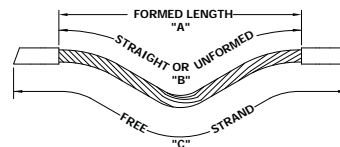

Bond Dimensions

Joint Head Bonds are fabricated from cadmium bronze signal bond strand conductor. Conductor consists of flexible stranded conductors (133 wires) made in rope lay construction consisting of one center strand of 19 wires surrounded by 6 strands of 19 wires each, diameter as specified with commercial tolerances allowed. Makeup of finished bond strand is nominal 3/16" diameter. 3/16" cadmium bronze bonds consist of strands of nominal 0.0125" diameter wire. Cadmium bronze bond strand has a minimal tensile strength of 55 KSI.

Bond Kit Includes:

- (100) Bonds
- (2) Replacement Molds
- (200) Cartridges of Weld Metal
- (1) Flint Igniter (Page 39)
- (For NUWTube kits only)



NUWTube®



UltraShot®

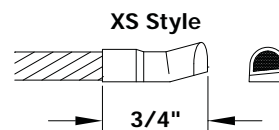

3/16" XS Style Bonds

XS Style Bond	NUWTube Bond Kit	US Bond Kit	Bond Only	Welder (molds & frame)	Frame Only
6.5" XS Bond	RBJHXS3/166.5KTNT	RBJHXS3/166.5KTUS	RBJHXS3/166.5	RMJHXS3/166.5T6	RMJH6.5T6FRM
7.5" XS Bond	RBJHXS3/167.5KTNT	RBJHXS3/167.5KTUS	RBJHXS3/167.5	RMJHXS3/167.5T6	RMJH7.5T6FRM
9.75" XS Bond	RBJHXS3/169.75KTNT	RBJHXS3/169.75KTUS	RBJHXS3/169.75	RMJHXS3/169.75T6	RMJH9.75T6FRM

• Replacement set of molds (left and right) for 3/16" XS Style Bonds are **RMJHXS3/16X**

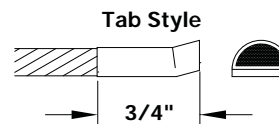

3/16" Tab Style Bonds

Tab Style Bond	NUWTube Bond Kit	US Bond Kit	Bond Only	Welder (molds & frame)	Frame Only
6.5" Tab Bond	RBJHTS3/166.5KTNT	RBJHTS3/166.5KTUS	RBJHTS3/166.5	RMJHTS3/166.5T6	RMJH6.5T6FRM
7.5" Tab Bond	RBJHTS3/167.5KTNT	RBJHTS3/167.5KTUS	RBJHTS3/167.5	RMJHTS3/167.5T6	RMJH7.5T6FRM
9.75" Tab Bond	RBJHTS3/169.75KTNT	RBJHTS3/169.75KTUS	RBJHTS3/169.75	RMJHTS3/169.75T6	RMJH9.75T6FRM

• Replacement set of molds (left and right) for 3/16" Tab Style Bonds are **RMJHTS3/16X**

ALL 3/16" Joint head bonds require either a NUWTUBE25R or US25R

- Joint Head Bonds meet requirements of AREMA 8.1.30
- Ultraweld exothermic materials meet requirements of AREMA 8.1.34
- Tinned electroplated bond strand available.
- Spare bond clips are BCLIP3/16



Mold Only Pair



Double Welder with Molds & Frame

5/16" Joint Head Bonds, Welders & Molds

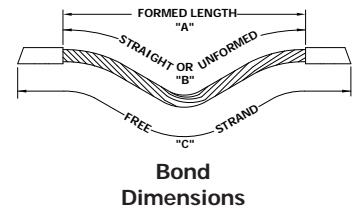
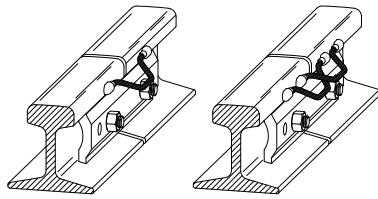

Joint Head Bonds are fabricated from cadmium bronze signal bond strand conductor. Conductor consists of flexible stranded conductors (133 wires) made in rope lay construction consisting of one center strand of 19 wires surrounded by 6 strands of 19 wires each, diameter as specified with commercial tolerances allowed. Makeup of finished bond strand is nominal 5/16" diameter. 5/16" cadmium bronze bonds consist of strands of nominal 0.0201" diameter wire. Cadmium bronze bond strand has a minimal tensile strength of 55 KSI.

Bond Kit Includes:

- (100) Bonds
- (2) Replacement Molds
- (200) Cartridges of Weld Metal
- (1) Flint Igniter (Page 39)
(For NUWTube kits only)

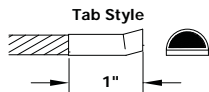

5/16" Tab Style Bonds

Tab Style Bond	NUWTube Bond Kit	US Bond Kit	Bond Only	Molds Only (LH & RH)	Welder Only (molds & frame)	Frame Only
7" Bond	RBJHTS5/167KTNT	RBJHTS5/167KTUS	RBJHTS5/167	RMJHTS5/16X	RMJHTS5/167T6	RMJH7T6FRM
9.75" Bond	RBJHTS5/169.75KTNT	RBJHTS5/169.75KTUS	RBJHTS5/169.75	RMJHTS5/16X	RMJHTS5/169.75T6	RMJH9.75T6FRM

ALL 5/16" Joint head bonds require either a NUWTUBE32R or US32R

- Joint Head Bonds meet requirements of AREMA 8.1.30
- Ultraweld exothermic materials meet requirements of AREMA 8.1.34
- Tinned electroplated bond strand available.
- Spare bond clips are BCLIP5/16

Single Rail Head Welders

Tab Style Bond	Welder Pair (LH & RH molds & frames)	Frame Only (LH & RH Pair)	Molds Only (LH & RH Pair)
3/16" - 3/4" Tab Style	RMJHTS3/16T7	RMJHT7FRM	RMJHTS3/16X
3/16" - 3/4" XS Style	RMJHXS3/16T7	RMJHT7FRM	RMJHXS3/16X
5/16" - 1 Tab Style	RMJHTS5/16T7	RMJHT7FRM	RMJHTS5/16X

- Rail Head "Single" Welders provide a means of attaching joint head bonds to the head of the rail when it is not convenient or possible to use a "Double" Welder such as transposed rail and compromise joints.
- Ultraweld exothermic materials meet requirements of AREMA 8.1.34.



Single Welder Pair (Molds & Frame)

Track Circuit Connectors (Web)

- Track Connectors are used when a compression connection is required, but the benefits of an exothermically welded connection are desired.
- Manufactured from 3/16" diameter cadmium bronze bond strand.
- Resists fatigue due to vibration and provides maximum flexibility.
- Track Connectors are available in kits or separately.

Track Connectors Kit Includes:

- (100) Track Connector Bonds
- (2) Replacement molds (left hand, right hand)
- (100) Cartridges of weld metal (Either UWTube25R or US25R)
- (1) Flint Igniter (Page 39) (For NUWTube kits only)

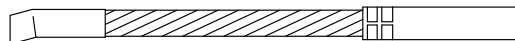

Track Connector

3/16" Diameter Track Connectors

Part No.	Description
RBTC3/164KTNT	NUWTube 1" Tab x 4" Long Bootleg (Kit)
RBTC3/164KTUS	UltraShot 1" Tab x 4" Long Bootleg (Kit)
RBTC3/164	1" Tab x 4" Long Bootleg (Track Connector Only)
RBTC3/1612KTNT	NUWTube 1" Tab x 12" Long Bootleg (Kit)
RBTC3/1612KTUS	UltraShot 1" Tab x 12" Long Bootleg (Kit)
RBTC3/1612	1" Tab x 12" Long Bootleg (Track Connector Only)

- Track Circuit Connectors meet requirements of AREMA 8.1.32.
- Ultraweld exothermic materials meet requirements of AREMA 8.1.34.
- Track Connectors require a Web Welder for welding to the rail web and compression tool MCT81/0.
- Tinned electroplated bond strand available.



1" x 3/16" Web Welder

Part No.	Description
RMWTS1-3/16T21	Welder Pair (LH & RH molds & frames)
RMWT21FRM	Frame Only
RMWTS1-3/16X	Molds Only (LH & RH Pair)

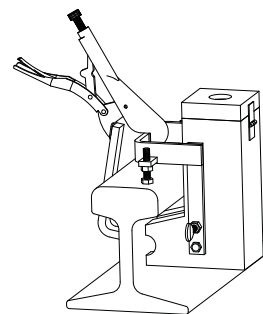

Mechanical Compression Tools

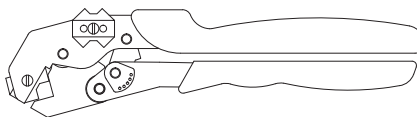

Part No.	Length	Approx. Wt. (lbs.)
MCT81/0	10.50	2

- Handy compression tool terminates copper compression connectors in wire sizes #8 AWG through 1/0.
- Handle length facilitates two-handed crimps when necessary.
- Approximately 2 tons of force.
- Dies included.

Jumper, Bootleg & Switch Bonds (Web)

- Bonds manufactured from 3/16" diameter cadmium bronze bond strand.
- Bonds are available in kits or separately.
- Mold(s) sold separately.

Bond Kit Includes:

- (100) Bonds
- (200) Cartridges of weld metal for Switch and Jumper Bonds
- OR
- (100) Cartridges of weld metal for Bootleg Bonds
- (1) Flint Igniter (Page 39) (For NUWTube kits only)

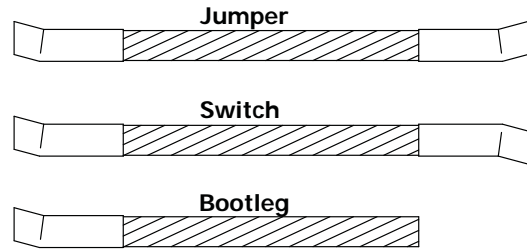

Cable Diameter	End Style	Parts	Jumper Part No.	Bootleg Part No.	Switch Part No.
3/16" Diameter Bonds	3/4" XS Style	UltraShot Bond Kit	RBJPXS3/16KTUS"L"	RBBLXS3/16KTUS"L"	RBSWXS3/16KTUS"L"
		NUWTube Bond Kit	RBJPXS3/16KTNT"L"	RBBLXS3/16KTNT"L"	RBSWXS3/16KTNT"L"
		Bond Only	RBJPXS3/16"L"	RBBLXS3/16"L"	RBSWXS3/16"L"
		Welder Pair	RMWXS3/16T21	RMWXS3/16T21	RMWXS3/16T21
		Molds Only (LH & RH Pair)	RMWXS3/16X	RMWXS3/16X	RMWXS3/16X
	3/4" Tab Style	UltraShot Bond Kit	RBJPTS.75-3/16KTUS"L"	RBBLTS.75-3/16KTUS"L"	RBSWTS.75-3/16KTUS"L"
		NUWTube Bond Kit	RBJPTS.75-3/16KTNT"L"	RBBLTS.75-3/16KTNT"L"	RBSWTS.75-3/16KTNT"L"
		Bond Only	RBJPTS.75-3/16"L"	RBBLTS.75-3/16"L"	RBSWTS.75-3/16"L"
		Welder Pair	RMWTS.75-3/16T21	RMWTS.75-3/16T21	RMWTS.75-3/16T21
		Molds Only (LH & RH Pair)	RMWTS.75-3/16X	RMWTS.75-3/16X	RMWTS.75-3/16X
	1" Tab Style	UltraShot Bond Kit	RBJPTS1-3/16KTUS"L"	RBBLTS1-3/16KTUS"L"	RBSWTS1-3/16KTUS"L"
		NUWTube Bond Kit	RBJPTS1-3/16KTNT"L"	RBBLTS1-3/16KTNT"L"	RBSWTS1-3/16KTNT"L"
		Bond Only	RBJPTS1-3/16"L"	RBBLTS1-3/16"L"	RBSWTS1-3/16"L"
		Welder Pair	RMWTS1-3/16T21	RMWTS1-3/16T21	RMWTS1-3/16T21
		Molds Only (LH & RH Pair)	RMWTS1-3/16X	RMWTS1-3/16X	RMWTS1-3/16X
	1-1/2" Tab Style	UltraShot Bond Kit	RBJPTS1.5-3/16KTUS"L"	RBBLTS1.5-3/16KTUS"L"	RBSWTS1.5-3/16KTUS"L"
		NUWTube Bond Kit	RBJPTS1.5-3/16KTNT"L"	RBBLTS1.5-3/16KTNT"L"	RBSWTS1.5-3/16KTNT"L"
		Bond Only	RBJPTS1.5-3/16"L"	RBBLTS1.5-3/16"L"	RBSWTS1.5-3/16"L"
		Welder Pair	RMWTS1.5-3/16T21	RMWTS1.5-3/16T21	RMWTS1.5-3/16T21
		Molds Only (LH & RH Pair)	RMWTS1.5-3/16X	RMWTS1.5-3/16X	RMWTS1.5-3/16X
5/16" Diameter Bonds	1" Tab Style	UltraShot Bond Kit	RBJPTS1-5/16KTUS"L"	RBBLTS1-5/16KTUS"L"	RBSWTS1-5/16KTUS"L"
		NUWTube Bond Kit	RBJPTS1-5/16KTNT"L"	RBBLTS1-5/16KTNT"L"	RBSWTS1-5/16KTNT"L"
		Bond Only	RBJPTS1-5/16"L"	RBBLTS1-5/16"L"	RBSWTS1-5/16"L"
		Welder Pair	RMWTS1-5/16T21	RMWTS1-5/16T21	RMWTS1-5/16T21
		Molds Only (LH & RH Pair)	RMWTS1-5/16X	RMWTS1-5/16X	RMWTS1-5/16X

All these connections use the RMWT21FRM frame.

- Substitute desired bond length in inches for "L".
- Bonds meet requirements of AREMA 8.1.32.
- Tinned electroplated bond strand available.



Field Made Tab Style Bonds

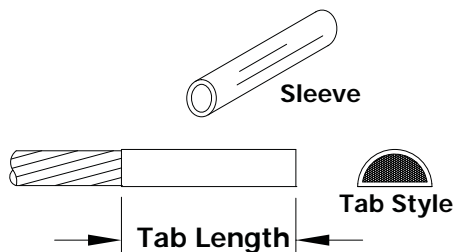

Bonds can be fabricated in the field by using Harger's easy to use Hammer Dies.

Cable Diameter	End Style	Parts	Jumper Part No.
3/16" Diameter Bond Strand	3/4" Tab Style	Sleeves Part No.*	BSLV3/16X.75
		Hammer Die Part No.	HMDIE3/16
		Welder Pair (LH & RH Molds & Frames)	RMWTS.75-3/16T21
		Molds Only (LH & RH Pair)	RMWTS.75-3/16X
	1" Tab Style	Sleeves Part No.*	BSLV3/16X1
		Hammer Die Part No.	HMDIE3/16
		Welder Pair (LH & RH Molds & Frames)	RMWTS1-3/16T21
		Molds Only (LH & RH Pair)	RMWTS1-3/16X
1-1/2" Tab Style	Sleeves Part No.*	BSLV3/16X1.5	
	Hammer Die Part No.	HMDIE3/16	
	Welder Pair (LH & RH Molds & Frames)	RMWTS1.5-3/16T21	
	Molds Only (LH & RH Pair)	RMWTS1.5-3/16X	
5/16" Diameter Bond Strand	1" Tab Style	Sleeves Part No.*	BSLV5/16X1
		Hammer Die Part No.	HMDIE5/16
		Welder Pair (LH & RH Molds & Frames)	RMWTS1-5/16T21
		Molds Only (LH & RH Pair)	RMWTS1-5/16X

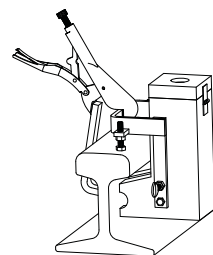

- All Field bonds use either a NUWTUBE25R or US25R.
 - All of these web welders use the RMWT21FRM.
 - Welders and Molds Only are supplied in pairs.
 - Frame Only is a single unit.
 - Ultraweld exothermic materials meet requirements of AREMA 8.1.34.
- * Box Qty. for sleeves is 100

Bond Strand Signal Cable

Part No.	Description
3/16CBWB	3/16 Cadmium Bronze Wire, Bare, 7x19x0.0125 Alloy 162
5/16CBWB	5/16 Cadmium Bronze Wire Bare, Bare, 7x19x0.0201 Alloy 162

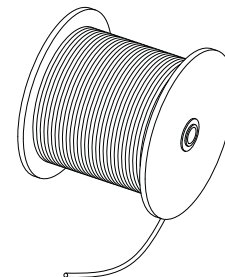

Propulsion Rail Head Bonds (C-Type)

Welded type propulsion (power) rail head bonds are for track circuits where such propulsion rail head bonds are designed to carry propulsion current. Intended for welding to the head of a 75 lb. rail and heavier. Used for joint bonding only in areas free of double flanged wheels and excessive traffic damage. If ampacity requirement can not be met with a single bond, two bonds installed in parallel will effectively double the ampacity.

- Installation of two bonds requires the use of 13" bonds.
- Bonds are available in kits or separately.

Bond Kit Includes:

- (80) Bonds
- (160) Cartridges of weld metal (NuwTube or UltraShot)
- (2) Replacement molds (left hand, right hand)
- (1) Flint Igniter (Page 39) (For NUWTube kits only)

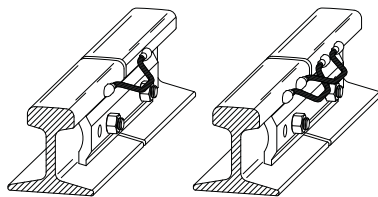
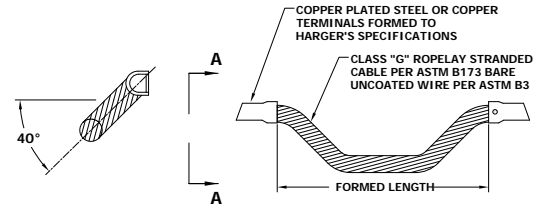

Size	Nominal Length*	Formed Length	NUWTube Bond Kit Part No.	UltraShot Bond Kit Part No.	Bond Only Part No.	UltraShot Size	NUWTube Size	Molds Only Pair (LH & RH) Part No.
2/0	9"	4-1/8"	RBJHC2/09KTNT	RBJHC2/09KTUS	RBJHC2/09	US65R	NUWTUBE65R	RMJHC2/0X
2/0	13"	8-1/4"	RBJHC2/013KTNT	RBJHC2/013KTUS	RBJHC2/013	US65R	NUWTUBE65R	RMJHC2/0X
4/0	9"	4-7/8"	RBJHC4/09KTNT	RBJHC4/09KTUS	RBJHC4/09	US90R	NUWTUBE90R	RMJHC4/0X
4/0	13"	7-7/8"	RBJHC4/013KTNT	RBJHC4/013KTUS	RBJHC4/013	US90R	NUWTUBE90R	RMJHC4/0X
250MCM	13"	7-7/8"	RBJHC25013KTNT	RBJHC25013KTUS	RBJHC25013	US90R	NUWTUBE90R	RMJHC250X

*Approximate bond length before forming



Bond Size	Bond Length	Molds Only Pair (LH & RH) Part No.	Double Welders		Single Welders	
			Welders Only (Molds & Frames) Part No.	Frame Only Part No.	Welder Pair Part No.	Frames Only (LH & RH Pair) Part No.
2/0	9"	RMJHC2/0X	RMJHC2/09T8	RMJHC2/09T8FRM	RMJHC2/0T9	RMJHC2/0T9FRM
2/0	13"	RMJHC2/0X	RMJHC2/013T8	RMJHC2/013T8FRM	RMJHC2/0T9	RMJHC2/0T9FRM
4/0	9"	RMJHC4/0X	RMJHC4/09T8	RMJHC4/09T8FRM	RMJHC4/0T9	RMJHC4/0T9FRM
4/0	13"	RMJHC4/0X	RMJHC4/013T8	RMJHC4/013T8FRM	RMJHC4/0T9	RMJHC4/0T9FRM
250MCM	13"	RMJHC250X	RMJHC25013T8	RMJHC25013T8FRM	RMJHC250T9	RMJHC250T9FRM

- Bond terminals are copper plated steel. Copper terminals are available on request.
- Bonds meet the requirements of AREMA 8.1.31.
- Weld metal meets requirements of AREMA 8.1.34.
- Individual molds can be purchased by putting LH or RH before the "X" in the mold only part number. Example: RMJHC2/0RHX
- Right Hand (RH) mold means cable exits mold to the right and Left Hand (LH) mold means cable exits on the left.

Propulsion Rail Head Bonds (C-Type)

Propulsion Web Bonds (W-Type)

- These Propulsion Rail-Web bonds are intended for welding to the web of a 75 lb. rail and heavier.
- Used for joint bonding and track connections for negative return (propulsion current).
- Web bonds can be connected to either the gauge or field side of the rail.

Stub End Bonds

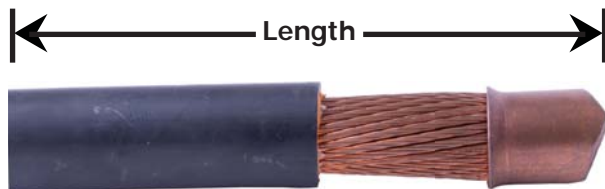

Example: 500 MCM insulated ropelay stub end bond 12" long.
Part No. RBWSE500RINS12

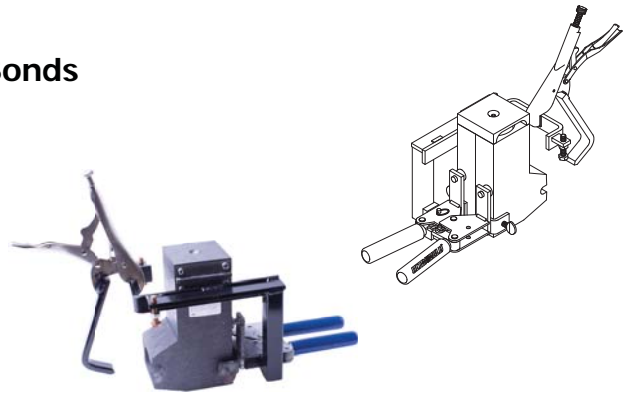

Left Hand mold and Frame

Stub End Bonds (Bare & Insulated)

Bond Configuration			Welding Materials			
Bond Size	Stub End (Bare) Part No.	Stub End (Insulated) Part No.	Welder Pair	UltraShot Weld Metal	NUWTUBE Weld Metal	Molds Only (pair) Part No.
1/0 Conc	RBWSE1/0B"L"	RBWSE1/0INS"L"	RMW1/0	US65R	NUWTUBE65R	RMW1/0X
1/0 Rope	RBWSE1/0RB"L"	RBWSE1/0RINS"L"	RMW1/0R	US65R	NUWTUBE65R	RMW1/0RX
2/0 Conc	RBWSE2/0B"L"	RBWSE2/0INS"L"	RMW2/0	US90R	NUWTUBE90R	RMW2/0X
2/0 Rope	RBWSE2/0RB"L"	RBWSE2/0RINS"L"	RMW2/0R	US90R	NUWTUBE90R	RMW2/0RX
4/0 Conc	RBWSE4/0B"L"	RBWSE4/0INS"L"	RMW4/0	US90R	NUWTUBE90R	RMW4/0X
4/0 Rope	RBWSE4/0RB"L"	RBWSE4/0RINS"L"	RMW4/0R	US90R	NUWTUBE90R	RMW4/0RX
250 Rope	RBWSE250RB"L"	RBWSE250RINS"L"	RMW250R	US115R	NUWTUBE115R	RMW250RX
300 Rope	RBWSE300RB"L"	RBWSE300RINS"L"	RMW300R	US150R	NUWTUBE150R	RMW300RX
350 Rope	RBWSE350RB"L"	RBWSE350RINS"L"	RMW350R	US150R	NUWTUBE150R	RMW350RX
500 Rope	RBWSE500RB"L"	RBWSE500RINS"L"	RMW500R	US250R	NUWTUBE250R	RMW500RX

- Order frame number **RMWC1x** where "x" is either "L" or "R". Example "R" is used when cable enters mold from right.
- Substitute desired bond length in inches for "L".
- Stub Bonds have a minimum length of 9".
- Stub Bonds meet the requirements of AREMA 8.1.33.
- Individual (single) welders or molds are available. Enter either RH or LH at the end of the Welder Pair part number or before the X in the Molds Only part number. Example: RMW4/0R-RH for a Right Hand Welder or RMW4/0R-RH-X for a Right Hand Mold Only. Left Hand mold would be required for bonds used above.
- Ultraweld exothermic materials meet the requirements of AREMA 8.1.34.
- For conductor specifications, see Page 22



Rail clamp is also available with a bar clamp for special applications. Please contact factory for more information.

Propulsion Web Bonds (W-Type)

Joint/Cross Bonds



Example: 250 MCM bare ropelay joint/cross bond 16" long.
Part No. RBWJC250RB16

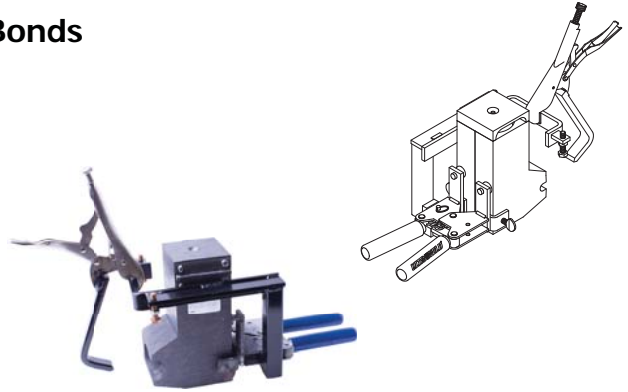

Left Hand mold and Frame

"L" Molds - Conductor exits to the left.
"R" Molds - Conductor exits to the right.

Joint/Cross Bonds (Bare & Insulated)

Bond Configuration			Welding Materials			
Bond Size	Stub End (Bare) Part No.	Stub End (Insulated) Part No.	Welder Pair	UltraShot Weld Metal	NUWTUBE Weld Metal	Molds Only (pair) Part No.
1/0 Conc	RBWJC1/0B"L"	RBWJC1/0INS"L"	RMW1/0	US65R	NUWTUBE65R	RMW1/0X
1/0 Rope	RBWJC1/0RB"L"	RBWJC1/0RINS"L"	RMW1/0R	US65R	NUWTUBE65R	RMW1/0RX
2/0 Conc	RBWJC2/0B"L"	RBWJC2/0INS"L"	RMW2/0	US90R	NUWTUBE90R	RMW2/0X
2/0 Rope	RBWJC2/0RB"L"	RBWJC2/0RINS"L"	RMW2/0R	US90R	NUWTUBE90R	RMW2/0RX
4/0 Conc	RBWJC4/0B"L"	RBWJC4/0INS"L"	RMW4/0	US90R	NUWTUBE90R	RMW4/0X
4/0 Rope	RBWJC4/0RB"L"	RBWJC4/0RINS"L"	RMW4/0R	US90R	NUWTUBE90R	RMW4/0RX
250 Rope	RBWJC250RB"L"	RBWJC250RINS"L"	RMW250R	US115R	NUWTUBE115R	RMW250RX
300 Rope	RBWJC300RB"L"	RBWJC300RINS"L"	RMW300R	US150R	NUWTUBE150R	RMW300RX
350 Rope	RBWJC350RB"L"	RBWJC350RINS"L"	RMW350R	US150R	NUWTUBE150R	RMW350RX
500 Rope	RBWJC500RB"L"	RBWJC500RINS"L"	RMW500R	US250R	NUWTUBE250R	RMW500RX

- Order frame number **RMWC1x** where "x" is either "L" or "R". Example "R" is used when cable enters mold from right.
- Substitute desired bond length in inches for "L".
- Joint Bonds must be 12" or greater than the Rail Angle Bar.
- Cross Bonds must be 14" or greater than the Track Gauge.
- Joint and Cross Bonds meet the requirements of AREMA 8.1.33.
- Individual (single) welders or molds are available. Enter either RH or LH at the end of the Welder Pair part number or before the X in the Molds Only part number. Example: RMW4/0R-**RH** for a Right Hand Welder or RMW4/0R-**RH**-X for a Right Hand Mold Only.
- Ultraweld exothermic materials meet the requirements of AREMA 8.1.34.
- For conductor specifications, see Page 22 .



Rail clamp is also available with a bar clamp for special applications.
Please contact factory for more information.

Web Grounding Connections

- Welded grounding connections to the web of 85 lb. to 140 lb. standard rails.
- If the ampacity requirement cannot be met with a single conductor, then two or more smaller conductors can be used.
- Mold frame includes adjusting screws to position the mold at the neutral axis of the rail.

Mold Information:

- Price Key is the **Bold Letter** in the Mold Part No.

Required Tools & Accessories:

- MH1 - Mold Handle Clamp (Page 42)
- RMWC1L- Rail Clamp
- Flint Igniter (FLTIG) included with MH1 (Page 39)

Recommended Tools & Accessories:

- CCBRSH2 - Cable Cleaning Brush - Heavy Duty (Page 40)
- MCBRSH1 - Mold Cleaning Brush (Page 41)
- RASP - Rasp for cleaning rail (Page 40)

RMVH

(Rail Mold Vertical Web Horizontal Cable)

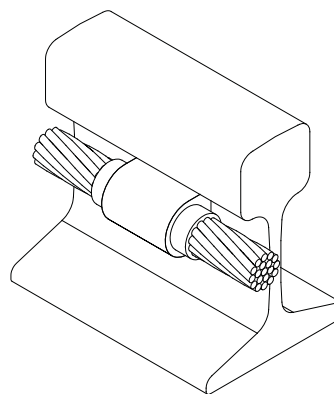

RMVH Connection Type

Size	Mold Part No.	UltraShot Weld Metal	NUWTube Weld Metal
4 Concentric	RMVH4WEBK	US90R	NUWTUBE90R
2 Concentric	RMVH2WEBK	US90R	NUWTUBE90R
1 Concentric	RMVH1WEBK	US90R	NUWTUBE90R
1/0 Concentric	RMVH1/0WEBK	US115R	NUWTUBE115R
2/0 Concentric	RMVH2/0WEBK	US115R	NUWTUBE115R
4/0 Concentric	RMVH4/0WEBK	US150R	NUWTUBE150R

- Ultraweld exothermic materials meet requirements of AREMA 8.1.34.

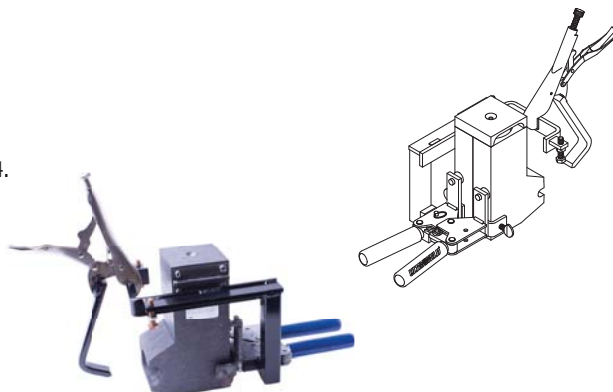

Left Hand mold and Frame

NOTES:
Mold Sealer required for 1/0 & larger conductor (Page 40)

The adjusting screws on mold frame position conductor at neutral axis of rail where stresses are minimal.



Rail clamp is also available with a bar clamp for special applications. Please contact factory for more information.

Web Grounding Connections

Mold Information:

- Molds listed are for concentric stranded cable.
- Price Key is the **Bold Letter** in the Mold Part No.

Required Tools & Accessories:

- MH1 - Mold Handle Clamp (Page 42)
- RMWC1L - Rail Clamp (Use with RMVL)
- RMWC1R - Rail Clamp (Use with RMVR)
- Flint Igniter (FLTIG) included with MH1 (Page 39)

Recommended Tools & Accessories:

- CCBRSH2 - Cable Cleaning Brush - Heavy Duty (Page 40)
- MCBRSH1 - Mold Cleaning Brushes (Page 41)
- RASP - Rasp for cleaning rail (Page 40)

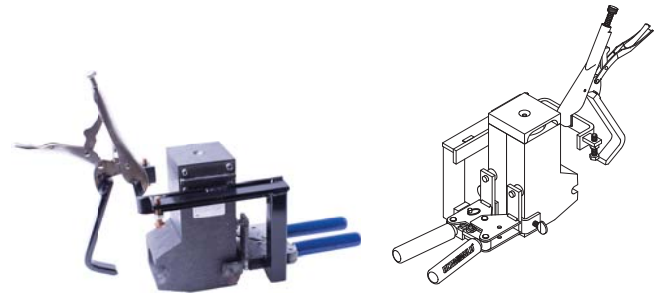

Left Hand mold and Frame

The adjusting screws on mold frame position conductor at neutral axis of rail where stresses are minimal.

RMVL

(Rail Mold Vertical Web Left Hand Mold)

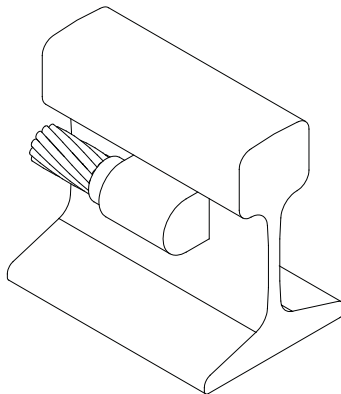

RMVR

(Rail Mold Vertical Web Right Hand Mold)

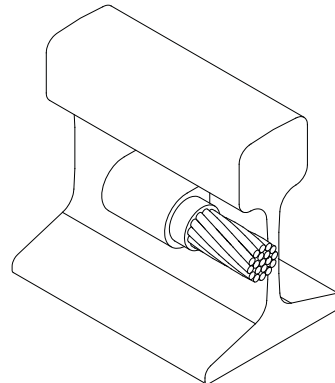

Size	Mold Part No.	Mold Part No.	UltraShot Weld Metal	NUWTube Weld Metal
4 Concentric	RMVL4WEBK	RMVR4WEBK	US65R	NUWTUBE65R
2 Concentric	RMVL2WEBK	RMVR2WEBK	US65R	NUWTUBE65R
1 Concentric	RMVL1WEBK	RMVR1WEBK	US65R	NUWTUBE65R
1/0 Concentric	RMVL1/0WEBK	RMVR1/0WEBK	US90R	NUWTUBE90R
2/0 Concentric	RMVL2/0WEBK	RMVR2/0WEBK	US90R	NUWTUBE90R
4/0 Concentric	RMVL4/0WEBK	RMVR4/0WEBK	US115R	NUWTUBE115R

RMVL the cable exits to the left.
 RMVR the cable exits mold to the right.

NOTES:
 Mold Sealer required for 1/0 & larger conductor (Page 40)



Rail clamp is also available with a bar clamp for special applications. Please contact factory for more information.

Conductor Specifications (C-Type Bonds)

Size	Nominal Length	# of Strands	Cable Class	Cable Lay
2/0	9"	133 (19 x 7)	G	4.99 in.
2/0	13"	133 (19 x 7)	G	4.99 in.
4/0	9"	133 (19 x 7)	G	5.50 in.
4/0	13"	133 (19 x 7)	G	5.50 in.
250 MCM	13"	259 (37 x 7)	G	5.70 in.

- Annealed copper per ASTM Specification B-3.
- Class G ropelay construction per ASTM B-173.

Conductor Specifications for Copper Ropelay (W-Type Bonds)

Size	O.D. (Inches)	# of Strands	Strand Diameter (Inches)	Cable Class
1/0	0.423	133 (19 x 7)	0.0282	G
2/0	0.474	133 (19 x 7)	0.0316	G
4/0	0.599	133 (19 x 7)	0.0399	G
250 MCM	0.653	259 (37.7 x 7)	0.0311	G
300 MCM	0.714	259 (37.7 x 7)	0.0340	G
350 MCM	0.773	259 (37.7 x 7)	0.0368	G
500 MCM	0.922	259 (37.7 x 7)	0.0439	G

- Annealed copper per ASTM Specification B-3.
- Class G ropelay construction per ASTM B-173.

Conductor Specifications for Copper Concentric Strand (W-Type Bonds)

Size	O.D. (Inches)	# of Strands	Strand Diameter (Inches)	Cable Class
1/0	0.373	19	0.0745	B
2/0	0.419	19	0.0837	B
4/0	0.528	19	0.1055	B
250 MCM	0.575	37	0.0822	B
300 MCM	0.630	37	0.0900	B
350 MCM	0.681	37	0.0973	B
500 MCM	0.813	37	0.1162	B

- Annealed copper per ASTM Specification B-3.
- Class B concentric strand per ASTM B-8.

Harger can manufacture a full range of premade bonds.
Below are some examples of custom bonds.



4 Finger Ballasted "ATR"
Head Negative Rail Tap



13" "ATR" Type Joint Bond

Aluminum to Copper Ground Studs

Signal Hut Grounding

Part No.	Description	Approx. Wt. (lbs.)
ASCACGS6SX36	ASC Al-Cu Ground Stud w/ #6 SOL x 3' Long	1
ASCACGS6SX48	ASC Al-Cu Ground Stud w/ #6 SOL x 4' Long	0.5
ASCACGS6SX60	ASC Al-Cu Ground Stud w/ #6 SOL x 5' Long	1
ASCACGS6SX72	ASC Al-Cu Ground Stud w/ #6 SOL x 6' Long	2

- Aluminum to Copper Bond Stud provides a permanent ground connection to aluminum signal bungalows and eliminates corrosion between copper and aluminum.
- Aluminum plate of the ground stud is GTAW or MGAW welded to the aluminum structure and the copper pigtail wire is exothermically welded to the ground electrode system.

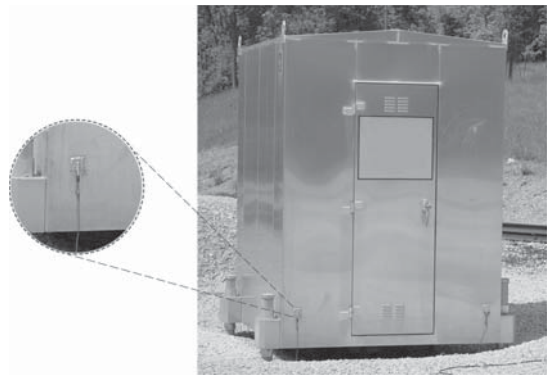

Steel Signal Case Ground Plates

Part No.	Description	Steel	Approx. Wt. (lbs.)
SSCGP6SX36	Steel Signal Case Ground Plate w/ #6 SOL x 3' Long	Mild Carbon	0.90
SSCGP6SX48	Steel Signal Case Ground Plate w/ #6 SOL x 4' Long	Mild Carbon	0.60
SSCGP6SX60	Steel Signal Case Ground Plate w/ #6 SOL x 5' Long	Mild Carbon	1.10
SSCGP6SX72	Steel Signal Case Ground Plate w/ #6 SOL x 6' Long	Mild Carbon	1.20
SSCGP6SX36SS	Steel Signal Case SS Ground Plate w/ #6 SOL x 3' Long	300 Series SS	0.90
SSCGP6SX48SS	Steel Signal Case SS Ground Plate w/ #6 SOL x 4' Long	300 Series SS	1
SSCGP6SX60SS	Steel Signal Case SS Ground Plate w/ #6 SOL x 5' Long	300 Series SS	1.10
SSCGP6SX72SS	Steel Signal Case SS Ground Plate w/ #6 SOL x 6' Long	300 Series SS	1.20

- For grounding steel signal huts and enclosures.
- Steel plates measure 1/4" x 2" x 2".

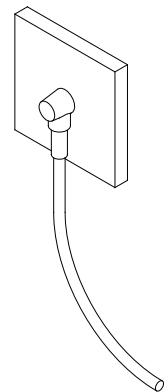

Feedthrough Stud

Part No.	Description	Approx. Wt. (lbs.)
ASCFS72	ASC Feedthrough Stud w/ #6 SOL x 6' Long	0.8

- Feedthrough Stud provides a convenient and permanent path for a ground conductor to pass through the wall of a structure.
- Stainless steel and tinned materials ensure resistance to corrosion.
- Protruding stud is used to either exothermically weld a ground conductor using Ultraweld mold HRCAD1/46SB (NUWTUBE45 or US45) or make a bolted lug connection.

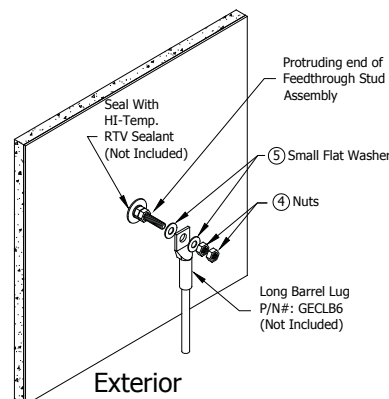
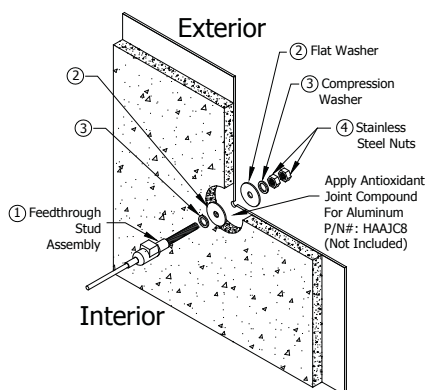

Mold Information:

- Price Key is the **Bold Letter** in the Mold Part No.
- Molds with Price Key "L" and "M" SOLD WITH HANDLES

Required Tools & Accessories:

- MH1 - Handle for "B" Price Key Molds (Page 42)
- MH2 - Handle for "C" Price Key Molds (Page 42)
- FLTIG - Flint Igniter when Price Key is "L" (Page 39)

Recommended Tools & Accessories:

- CCBRSH1 - Cable Cleaning Brush (Page 40)
- MCBRSH1 - Mold Cleaning Brushes (Page 41)

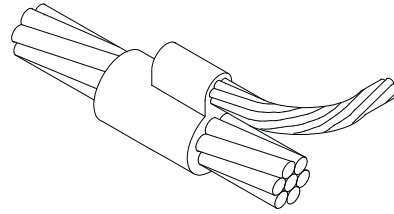

PB

(Parallel Butt)

PB Connection Type

Cable Size		Mold Part No.	Weld Metal	
Run	Tap		NUWTube	UltraShot
#6 SOL	#6 SOL	PB6S6SB	NUWTUBE25	US25
#4 STR	#8 SOL	PB48SB	NUWTUBE32	US32
	#6 SOL	PB46SB	NUWTUBE32	US32
	#6 STR	PB46B	NUWTUBE32	US32
	#4 STR	PB44B	NUWTUBE32	US32
#2 SOL	#2 SOL	PB2S2SB	NUWTUBE65	US65
#2 STR	#8 SOL	PB28SB	NUWTUBE32	US32
	#6 SOL	PB26SB	NUWTUBE32	US32
	#6 STR	PB26B	NUWTUBE32	US32
	#4 STR	PB24B	NUWTUBE45	US45
	#2 STR	PB22B	NUWTUBE65	US65

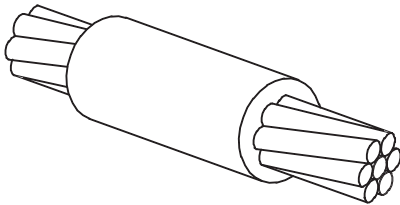

BS

(Butt Splice Cables)

BS Connection Type

Cable Size	Mold Part No.	Weld Metal	
		NUWTube	UltraShot
#6 SOL	BS6SL	NUWTUBE25	US25
#6 STR	BS6L	NUWTUBE25	US25
#4 STR	BS4L	NUWTUBE25	US25
#2 STR	BS2L	NUWTUBE32	US32
#1 STR	BS1L	NUWTUBE32	US32
1/0 STR	BS1/0B	NUWTUBE45	US45
2/0 STR	BS2/0B	NUWTUBE65	US65
3/0 STR	BS3/0B	NUWTUBE90	US90
4/0 STR	BS4/0B	NUWTUBE90	US90
250 MCM	BS25CMB	NUWTUBE115	US115
300 MCM	BS3CMB	NUWTUBE115	US115
350 MCM	BS35CMB	NUWTUBE150	US150
500 MCM	BS5CMB	NUWTUBE200	US200
750 MCM	BS75CMC	NUWTUBE2X150	US300
1000 MCM	BS1MMC	NUWTUBE2X200	US400

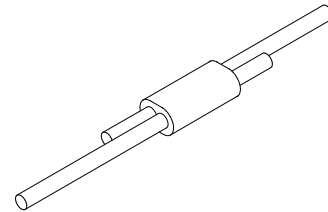

PS

(Parallel Splice)

PS Connection Type

Cable Size		Mold Part No.	Weld Metal	
Run	Tap		NUWTube	UltraShot
#8 SOL	#8 SOL	PS8S8SL	NUWTUBE25	US25
#8 STR	#8 STR	PS88L	NUWTUBE25	US25
#6 SOL	#6 SOL	PS6S6SL	NUWTUBE25	US25
#6 STR	#6 STR	PS66L	NUWTUBE25	US25

Mold Information:

- Price Key is the **Bold Letter** in the Mold Part No.

Required Tools & Accessories:

MH1 - Mold Handle Clamp (Page 42)

Recommended Tools & Accessories:

CCBRSH1 - Cable Cleaning Brush (Page 40)

MCBRSH1 - Mold Cleaning Brushes (Page 41)

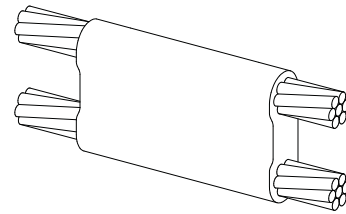

PT

(Parallel Thru Cables)

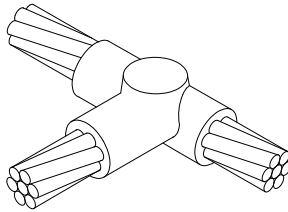

RT

(Run & Tap)

RT Connection Type

Cable Size		Mold Part No.	Weld Metal	
Run	Tap		NUWTube	UltraShot
#6 SOL	#6 SOL	RT6S6SB	NUWTUBE32	US32
#6 STR	#6 STR	RT66B	NUWTUBE32	US32
#4 STR	#4 STR	RT44B	NUWTUBE32	US32
#2 SOL	#2 SOL	RT2S2SB	NUWTUBE45	US45
#2 STR	#4 STR	RT24B	NUWTUBE45	US45
	#2 STR	RT22B	NUWTUBE45	US45
1/0 STR	#4 STR	RT1/04B	NUWTUBE45	US45
	#2 STR	RT1/02B	NUWTUBE45	US45
	#1 STR	RT1/01B	NUWTUBE45	US45
	1/0 STR	RT1/01/0B	NUWTUBE90	US90
2/0 STR	#4 STR	RT2/04B	NUWTUBE45	US45
	#2 STR	RT2/02B	NUWTUBE45	US45
	#1 STR	RT2/01B	NUWTUBE45	US45
	1/0 STR	RT2/01/0B	NUWTUBE90	US90
	2/0 STR	RT2/02/0B	NUWTUBE90	US90
3/0 STR	#4 STR	RT3/04B	NUWTUBE45	US45
	#2 STR	RT3/02B	NUWTUBE45	US45
	1/0 STR	RT3/01/0B	NUWTUBE90	US90
	2/0 STR	RT3/02/0B	NUWTUBE90	US90
	3/0 STR	RT3/03/0B	NUWTUBE115	US115
4/0 STR	#4 STR	RT4/04B	NUWTUBE90	US90
	#2 STR	RT4/02B	NUWTUBE90	US90
	#1 STR	RT4/01B	NUWTUBE90	US90
	1/0 STR	RT4/01/0B	NUWTUBE90	US90
	2/0 STR	RT4/02/0B	NUWTUBE90	US90
	3/0 STR	RT4/03/0B	NUWTUBE115	US115
	4/0 STR	RT4/04/0B	NUWTUBE150	US150

PT Connection Type

Cable Size		Mold Part No.	Weld Metal	
Run	Tap		NUWTube	UltraShot
#6 SOL	#6 SOL	PT6S6SB	NUWTUBE25	US25
#6 STR	#6 STR	PT66B	NUWTUBE25	US25
#4 STR	#8 SOL	PT48SB	NUWTUBE32	US32
	#8 STR	PT48B	NUWTUBE32	US32
	#6 SOL	PT46SB	NUWTUBE32	US32
	#6 STR	PT46B	NUWTUBE32	US32
	#4 STR	PT44B	NUWTUBE32	US32
#2 SOL	#2 SOL	PT2S2SB	NUWTUBE65	US65
#2 STR	#8 SOL	PT28SB	NUWTUBE45	US45
	#8 STR	PT28B	NUWTUBE45	US45
	#6 SOL	PT26SB	NUWTUBE45	US45
	#6 STR	PT26B	NUWTUBE45	US45
	#4 STR	PT24B	NUWTUBE65	US65
	#2 STR	PT22B	NUWTUBE65	US65
2/0 STR	#8 SOL	PT2/08SB	NUWTUBE65	US65
	#8 STR	PT2/08B	NUWTUBE65	US65
	#6 SOL	PT2/06SB	NUWTUBE90	US90
	#6 STR	PT2/06B	NUWTUBE90	US90
	#4 STR	PT2/04B	NUWTUBE90	US90
	#2 STR	PT2/02B	NUWTUBE90	US90
	#1 STR	PT2/01B	NUWTUBE90	US90
	1/0 STR	PT2/01/0B	NUWTUBE115	US115
	2/0 STR	PT2/02/0B	NUWTUBE115	US115
	4/0 STR	#8 SOL	PT4/08SB	NUWTUBE90
#8 STR		PT4/08B	NUWTUBE90	US90
#6 SOL		PT4/06SB	NUWTUBE90	US90
#6 STR		PT4/06B	NUWTUBE90	US90
#4 STR		PT4/04B	NUWTUBE150	US150
#2 STR		PT4/02B	NUWTUBE150	US150
#1 STR		PT4/01B	NUWTUBE150	US150
1/0 STR		PT4/01/0B	NUWTUBE150	US150
2/0 STR		PT4/02/0B	NUWTUBE150	US150
3/0 STR		PT4/03/0B	NUWTUBE200	US200
4/0 STR	PT4/04/0B	NUWTUBE200	US200	

Mold Information:

- Molds listed are for copper clad ground rods
- For threaded sectional rods, add suffix "S" after the ground rod number. i.e. 58S = 5/8" sectional ground rod.
- For Full size rods, add suffix "F" after the ground rod number. i.e. 58F = 5/8" Full Size rod.
- Molds with Price Key "L" SOLD WITH HANDLES but not igniter.
- Price Key is the **Bold Letter** in the Mold Part No.
- All 1/2 rods are assumed to be a full 1/2 inch unless specified differently.

Required Tools & Accessories:

- MH1 - Handle for "B" Price Key Molds (Page 42)
- FLTIG - Flint Igniter when Price Key is "L" (Page 39)

Recommended Tools & Accessories:

- CCBRSH1 - Cable Cleaning Brush (Page 40)
- MCBRSH1 - Mold Cleaning Brushes (Page 41)

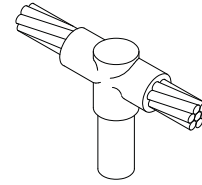

GO

(Ground Rod to Cable Over Top)

GO Connection Type

Ground Rod Size	Cable Size	Mold Part No.	Weld Metal	
			NUWTube	UltraShot
1/2" GRD ROD	#6 STR	GO126L	NUWTUBE32	US32
	#4 STR	GO124L	NUWTUBE32	US32
	#2 STR	GO122B	NUWTUBE90	US90
	2/0 STR	GO122/0B	NUWTUBE90	US90
	4/0 STR	GO124/0B	NUWTUBE115	US115
5/8" GRD ROD	#6 STR	GO586L	NUWTUBE32	US32
	#4 STR	GO584L	NUWTUBE32	US32
	#2 SOL	GO582SB	NUWTUBE90	US90
	#2 STR	GO582B	NUWTUBE90	US90
	1/0 STR	GO581/0B	NUWTUBE90	US90
	2/0 STR	GO582/0B	NUWTUBE115	US115
	4/0 STR	GO584/0B	NUWTUBE115	US115
250 MCM	GO5825CMB	NUWTUBE150	US150	
3/4" GRD ROD	#6 STR	GO346L	NUWTUBE45	US45
	#4 STR	GO344M	NUWTUBE65	US65
	#2 SOL	GO342SB	NUWTUBE90	US90
	#2 STR	GO342B	NUWTUBE90	US90
	1/0 STR	GO341/0B	NUWTUBE115	US115
	2/0 STR	GO342/0B	NUWTUBE115	US115
	4/0 STR	GO344/0B	NUWTUBE115	US115
	250 MCM	GO3425CMB	NUWTUBE150	US150
	1" GRD ROD	2/0 STR	GO102/0B	NUWTUBE150
4/0 STR	GO104/0B	NUWTUBE150	US150	
250 MCM	GO1025CMB	NUWTUBE200	US200	

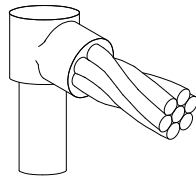

GD

(Ground Rod to Dead End Cable)

GD Connection Type

Ground Rod Size	Cable Size	Mold Part No.	Weld Metal	
			NUWTube	UltraShot
1/2" GRD ROD	#6 STR	GD126L	NUWTUBE25	US25
	#4 STR	GD124L	NUWTUBE25	US25
	#2 STR	GD122B	NUWTUBE65	US65
	2/0 STR	GD122/0B	NUWTUBE90	US90
	4/0 STR	GD124/0B	NUWTUBE90	US90
5/8" GRD ROD	#6 STR	GD586L	NUWTUBE32	US32
	#4 STR	GD584L	NUWTUBE32	US32
	#2 SOL	GD582SB	NUWTUBE65	US65
	#2 STR	GD582B	NUWTUBE65	US65
	1/0 STR	GD581/0B	NUWTUBE90	US90
	2/0 STR	GD582/0B	NUWTUBE90	US90
	4/0 STR	GD584/0B	NUWTUBE90	US90
250 MCM	GD5825CMB	NUWTUBE90	US90	
3/4" GRD ROD	#6 STR	GD346L	NUWTUBE32	US32
	#4 STR	GD344L	NUWTUBE45	US45
	#2 SOL	GD342SB	NUWTUBE90	US90
	4/0 STR	GD344/0B	NUWTUBE90	US90
	#2 STR	GD342B	NUWTUBE90	US90
	1/0 STR	GD341/0B	NUWTUBE90	US90
	2/0 STR	GD342/0B	NUWTUBE90	US90
250 MCM	GD3425CMB	NUWTUBE90	US90	
1" GRD ROD	2/0 STR	GD102/0B	NUWTUBE150	US150
	4/0 STR	GD104/0B	NUWTUBE150	US150
	250 MCM	GD1025CMB	NUWTUBE150	US150

NOTE:

- Molds listed are for copperclad steel ground rods.
- For welding to full size copperclad steel, stainless steel, galvanized steel or solid copper ground rods, add letter "F" to ground rod size.

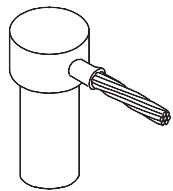

G11

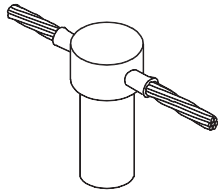

G21

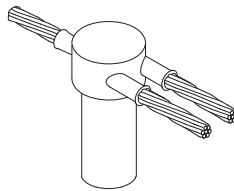

G31

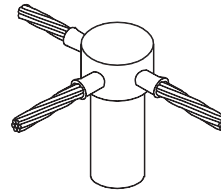

G31*

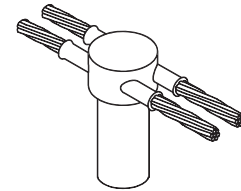

G41



Uni-Shots - UltraShot®

Type	Cable Sizes		Ground Rod			
	Solid	Stranded	5/8 Copper Clad	5/8 Full	3/4 Copper Clad	3/4 Full
G11	#6, #8	#8	G11588US	G1158F8US	G11348US	G1134F8US
G11	#3, #4	#4, #6	G11584US	G1158F4US	G11344US	G1134F4US
G11	#1, #2	#2, #3	G11582US	G1158F2US	G11342US	G1134F2US
G11	2/0, 1/0	1/0, #1	G11581/0US	G1158F1/0US	G11341/0US	G1134F1/0US
G11	-	2/0	G11582/0US	G1158F2/0US	G11342/0US	G1134F2/0US
G11		4/0	G11584/0US	G1158F4/0US	G11344/0US	G1134F4/0US
G21	#6, #8	#8	G21588US	G2158F8US	G21348US	G2134F8US
G21	#3, #4	#4, #6	G21584US	G2158F4US	G21344US	G2134F4US
G21	#1, #2	#2, #3	G21582US	G2158F2US	G21342US	G2134F2US
G21	2/0, 1/0	1/0, #1	G21581/0US	G3158F1/0US	G21341/0US	G2134F1/0US
G21		2/0	G21582/0US	G3158F2/0US	G21342/0US	G21342/0US
G21		4/0	G21584/0US	G3158F4/0US	G21344/0US	G21344/0US
G31	#6, #8	#8	G31588US	G3158F8US	G31348US	G3134F8US
G31	#3, #4	#4, #6	G31584US	G3158F4US	G31344US	G3134F4US
G31	#1, #2	#2, #3	G31582US	G3158F2US	G31342US	G3134F2US
G31	2/0, 1/0	1/0, #1	G31581/0US	G3158F1/0US*	G31341/0US	G3134F1/0US*
G41	#6, #8	#8	G41588US	G4158F8US	G41348US	G4134F8US
G41	#3, #4	#4, #6	G41584US	G4158F4US	G41344US	G4134F4US
G41	#1, #2	#2, #3	G41582US	G4158F2US	G41342US	G4134F2US

NOTES:

- Disposable single use ceramic mold provides convenience and ease of use.
- Packaged 12 per box.
- No frames or handle clamps are required.
- Drone required to make UltraShot Uni-Shot connection. See page 38.

Use locking pliers to support mold



UltraShot
(Electronic)

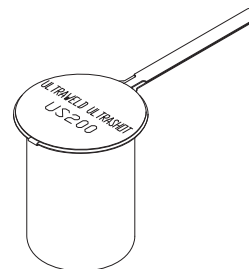

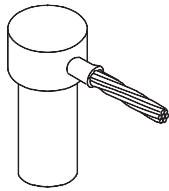

G11

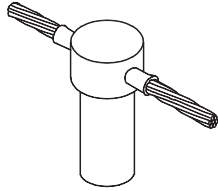

G21

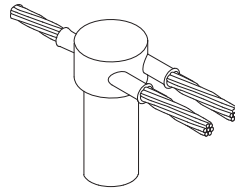

G31

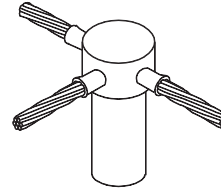

G31*

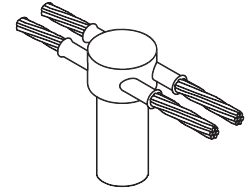

G41



Uni-Shots - NUWTube®

Type	Cable Sizes		Ground Rod			
	Solid	Stranded	5/8 Copper Clad	5/8 Full	3/4 Copper Clad	3/4 Full
G11	#6, #8	#8	G11588NU	G1158F8NU	G11348NU	G1134F8NU
G11	#3, #4	#4, #6	G11584NU	G1158F4NU	G11344NU	G1134F4NU
G11	#1, #2	#2, #3	G11582NU	G1158F2NU	G11342NU	G1134F2NU
G11	2/0, 1/0	1/0, #1	G11581/0NU	G1158F1/0NU	G11341/0NU	G1134F1/0NU
G11	-	2/0	G11582/0NU	G1158F2/0NU	G11342/0NU	G1134F2/0NU
G11	-	4/0	G11584/0NU	G1158F4/0NU	G11344/0NU	G1134F4/0NU
G21	#6, #8	#8	G21588NU	G2158F8NU	G21348NU	G2134F8NU
G21	#3, #4	#4, #6	G21584NU	G2158F4NU	G21344NU	G2134F4NU
G21	#1, #2	#2, #3	G21582NU	G2158F2NU	G21342NU	G2134F2NU
G21	2/0, 1/0	1/0, #1	G21581/0NU	G3158F1/0NU	G21341/0NU	G2134F1/0NU
G21	-	2/0	G21582/0NU	G3158F2/0NU	G21342/0NU	G2134F2/0NU
G21	-	4/0	G21584/0NU	G3158F4/0NU	G21344/0NU	G2134F4/0NU
G31	#6, #8	#8	G31588NU	G3158F8NU	G31348NU	G3134F8NU
G31	#3, #4	#4, #6	G31584NU	G3158F4NU	G31344NU	G3134F4NU
G31	#1, #2	#2, #3	G31582NU	G3158F2NU	G31342NU	G3134F2NU
G31	2/0, 1/0	1/0, #1	G31581/0NU	G3158F1/0NU*	G31341/0NU	G3134F1/0NU*
G41	#6, #8	#8	G41588NU	G4158F8NU	G41348NU	G4134F8NU
G41	#3, #4	#4, #6	G41584NU	G4158F4NU	G41344NU	G4134F4NU
G41	#1, #2	#2, #3	G41582NU	G4158F2NU	G41342NU	G4134F2NU

NOTES:

- Disposable single use ceramic mold provides convenience and ease of use.
- Packaged 12 per box.
- Requires only a Flint Igniter (FLTIG) to make a connection. See Page 39.
- No frames or handle clamps are required.

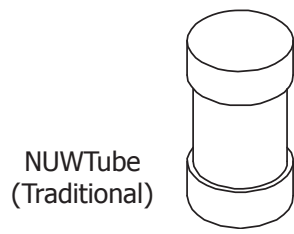
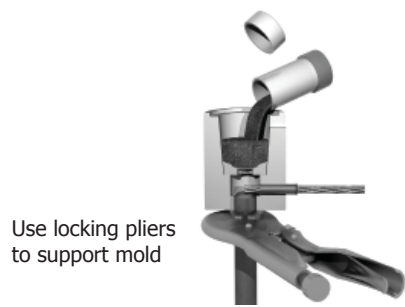

Ultraweld Connections

Mold Information:

- Molds with Price Key "A" SOLD WITH FRAME.
- Frame for "A" Price Key Molds INCLUDES Flint Igniters.
- Price Key is the **Bold Letter** in the Mold Part No.

Required Tools & Accessories:

- MH1 - Handle for "B" Price Key Molds (Page 42)
- MH2 - Handle for "C" Price Key Molds (Page 42)

Recommended Tools & Accessories:

- CCBRSH1 - Cable Cleaning Brush (Page 40)
- MCBRSH1 - Mold Cleaning Brushes (Page 41)
- UMHDKIT - Hold Down Kit (Page 43)

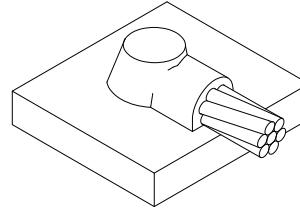

HD

(Horizontal Butt DOWN on Surface)

HD Connection Type

Cable Size	Mold Part No.	Weld Metal	
		NUWTube	UltraShot
#6 SOL	HD6SA	NUWTUBE45	US45
#6 STR	HD6A	NUWTUBE45	US45
#4 STR	HD4A	NUWTUBE45	US45
#2 SOL	HD2SA	NUWTUBE45	US45
#2 STR	HD2A	NUWTUBE45	US45
1/0 STR	HD1/0B	NUWTUBE90	US90
2/0 STR	HD2/0B	NUWTUBE90	US90
3/0 STR	HD3/0B	NUWTUBE115	US115
4/0 STR	HD4/0B	NUWTUBE115	US115
250 MCM	HD25CMB	NUWTUBE115	US115
300 MCM	HD3CMB	NUWTUBE150	US150
350 MCM	HD35CMB	NUWTUBE200	US200
500 MCM	HD5CMB	NUWTUBE200	US200
750 MCM	HD75CMC	NUWTUBE2X150	US300
1000 MCM	HD1MMC	NUWTUBE2X200	US400

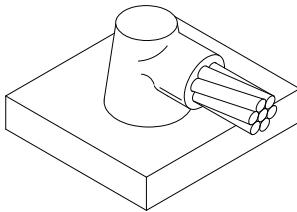

HB

(Horizontal Butt OFF Surface)

HB Connection Type

Cable Size	Mold Part No.	Weld Metal	
		NUWTube	UltraShot
#6 STR	HB6B	NUWTUBE65	US65
#2 SOL	HB2SB	NUWTUBE65	US65
#2 STR	HB2B	NUWTUBE65	US65
1/0 STR	HB1/0B	NUWTUBE90	US90
2/0 STR	HB2/0B	NUWTUBE90	US90
3/0 STR	HB3/0B	NUWTUBE115	US115
4/0 STR	HB4/0B	NUWTUBE115	US115
250 MCM	HB25CMB	NUWTUBE115	US115
300 MCM	HB3CMB	NUWTUBE150	US150
350 MCM	HB35CMB	NUWTUBE200	US200
500 MCM	HB5CMB	NUWTUBE200	US200
750 MCM	HB75CMC	NUWTUBE2X150	US300
1000 MCM	HB1MMC	NUWTUBE2X200	US400

NOTES:

- All HD welds 1/0 and bigger require Mold Sealer (Page 40) to make a weld.

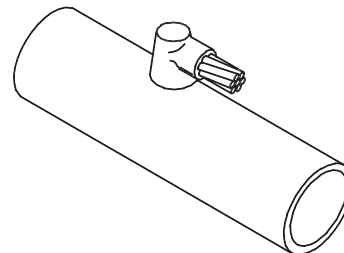

For HB or HD molds to horizontal pipe, please contact the factory.

Mold Information:

- Price Key is the **Bold Letter** in the Mold Part No.

Required Tools & Accessories:

- MH1 - Handle for "B" Price Key Molds (Page 42)
- MH2 - Handle for "C" Price Key Molds (Page 42)

Recommended Tools & Accessories:

- CCBRSH1 - Cable Cleaning Brush (Page 40)
- MCBRSH1 - Mold Cleaning Brushes (Page 41)
- MSKIT - Magnetic Support Kit (Page 42) (Requires 8" wide steel to use)

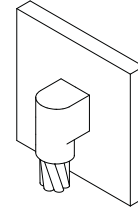

VD

(Vertical Down)

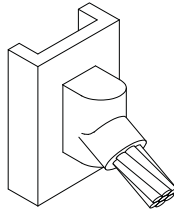

VA

(Vertical Angle 45°)

VA Connection Type

Cable Size	Mold Part No.	Weld Metal	
		NUWTube	UltraShot
#6 STR	VA6 B	NUWTUBE45	US45
#4 STR	VA4 B	NUWTUBE45	US45
#2 SOL	VA2 SB	NUWTUBE45	US45
#2 STR	VA2 B	NUWTUBE45	US45
1/0 STR	VA1/0 B	NUWTUBE90	US90
2/0 STR	VA2/0 B	NUWTUBE90	US90
3/0 STR	VA3/0 B	NUWTUBE115	US115
4/0 STR	VA4/0 B	NUWTUBE115	US115
250 MCM	VA25 CMB	NUWTUBE115	US115
300 MCM	VA3 CMB	NUWTUBE150	US150
350 MCM	VA35 CMB	NUWTUBE200	US200
500 MCM	VA5 CMB	NUWTUBE200	US200
750 MCM	VA75 CMC	NUWTUBE2X150	US300
1000 MCM	VA1 MMC	NUWTUBE2X200	US400

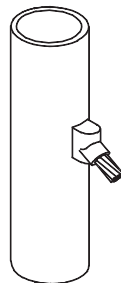

For VD or VA molds to vertical or horizontal pipe, please contact the factory.

VD Connection Type

Cable Size	Mold Part No.	Weld Metal	
		NUWTube	UltraShot
#6 STR	VD6 B	NUWTUBE45	US45
#4 STR	VD4 B	NUWTUBE65	US65
#2 SOL	VD2 SB	NUWTUBE65	US65
#2 SOL	VD2SV1.25X4 B	NUWTUBE65	US65
#2 STR	VD2 B	NUWTUBE65	US65
1/0 STR	VD1/0 B	NUWTUBE115	US115
2/0 STR	VD2/0 B	NUWTUBE115	US115
2/0 STR	VD2/0V1.25X4 B	NUWTUBE115	US115
3/0 STR	VD3/0 B	NUWTUBE150	US150
4/0 STR	VD4/0 B	NUWTUBE150	US150
4/0 STR	VD4/0V1.25X4 B	NUWTUBE150	US150
250 MCM	VD25 CMB	NUWTUBE200	US200
300 MCM	VD3 CMB	NUWTUBE200	US200
350 MCM	VD35 CMB	NUWTUBE250	US250
500 MCM	VD5 CMK	NUWTUBE2X150	US300



MSKIT

MSHC1

Magnetic Support Handle Clamp allows mold to be securely held in place to steel surfaces.

Mold Information:

- Price Key is the **Bold Letter** in the Mold Part No.

Required Tools & Accessories:

- MH1 - Handle for "B" and "K" Price Key Molds (Page 42)
- MH2 - Handle for "C" Price Key Molds (Page 42)

Recommended Tools & Accessories:

- CCBRSH1 - Cable Cleaning Brush (Page 40)
- MCBRSH1 - Mold Cleaning Brushes (Page 41)
- MSKIT - Magnetic Support Kit (Page 42)

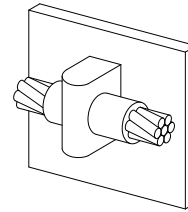

VH

(Vertical Surface Horizontal Cable)

VH Connection Type

Cable Size	Mold Part No.	Weld Metal	
		NUWTube	UltraShot
#6 STR	VH6 B	NUWTUBE65	US65
#4 STR	VH4 B	NUWTUBE65	US65
#2 SOL	VH2 SB	NUWTUBE65	US65
#2 STR	VH2 B	NUWTUBE65	US65
1/0 STR	VH1/0 B	NUWTUBE115	US115
2/0 STR	VH2/0 B	NUWTUBE115	US115
3/0 STR	VH3/0 B	NUWTUBE150	US150
4/0 STR	VH4/0 B	NUWTUBE150	US150
250 MCM	VH25 CMB	NUWTUBE150	US150
500 MCM	VH5 CMC	NUWTUBE2X150	US300

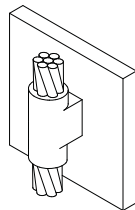

VT

(Vertical Thru off Vertical Surface)

VT Connection Type

Cable Size	Mold Part No.	Weld Metal	
		NUWTube	UltraShot
#6 STR	VT6 B	NUWTUBE90	US90
#4 STR	VT4 B	NUWTUBE90	US90
#2 SOL	VT2 SB	NUWTUBE115	US115
#2 STR	VT2 B	NUWTUBE115	US115
1/0 STR	VT1/0 K	NUWTUBE200	US200
2/0 STR	VT2/0 K	NUWTUBE200	US200
3/0 STR	VT3/0 K	NUWTUBE250	US250
4/0 STR	VT4/0 K	NUWTUBE250	US250
250 MCM	VT25 CMK	NUWTUBE250	US250

Mold Information:

- Price Key is the **Bold Letter** in the Mold Part No.

Required Tools & Accessories:

MH1 - Mold Handle Clamp (Page 42)

Recommended Tools & Accessories:

CCBRSH1 - Cable Cleaning Brush (Page 40)

MCBRSH1 - Mold Cleaning Brushes (Page 41)

MSKIT - Magnetic Support Kit (Page 42)

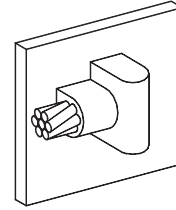

VL

(Vertical Surface Left Hand Mold)

VL Connection Type

Cable Size	Mold Part No.	Weld Metal	
		NUWTube	UltraShot
#6 STR	VL6 B	NUWTUBE45	US45
#4 STR	VL4 B	NUWTUBE45	US45
#2 SOL	VL2 SB	NUWTUBE45	US45
#2 STR	VL2 B	NUWTUBE45	US45
1/0 STR	VL1/0 B	NUWTUBE90	US90
2/0 STR	VL2/0 B	NUWTUBE90	US90
3/0 STR	VL3/0 B	NUWTUBE115	US115
4/0 STR	VL4/0 B	NUWTUBE115	US115
250 MCM	VL25 CMB	NUWTUBE115	US115
300 MCM	VL3 CMB	NUWTUBE150	US150
350 MCM	VL35 CMB	NUWTUBE200	US200
500 MCM	VL5 CMB	NUWTUBE200	US200

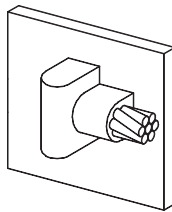

VR

(Vertical Surface Right Hand Mold)

VR Connection Type

Cable Size	Mold Part No.	Weld Metal	
		NUWTube	UltraShot
#6 STR	VR6 B	NUWTUBE45	US45
#4 STR	VR4 B	NUWTUBE45	US45
#2 SOL	VR2 SB	NUWTUBE45	US45
#2 STR	VR2 B	NUWTUBE45	US45
1/0 STR	VR1/0 B	NUWTUBE90	US90
2/0 STR	VR2/0 B	NUWTUBE90	US90
3/0 STR	VR3/0 B	NUWTUBE115	US115
4/0 STR	VR4/0 B	NUWTUBE115	US115
250 MCM	VR25 CMB	NUWTUBE115	US115
300 MCM	VR3 CMB	NUWTUBE150	US150
350 MCM	VR35 CMB	NUWTUBE200	US200
500 MCM	VR5 CMB	NUWTUBE200	US200

NOTES:

- Mold Sealer required for 1/0 & larger conductor (Page 40)

Mold Information:

- Price Key is the **Bold Letter** in the Mold Part No.

Required Tools & Accessories:

- MH1 - Handle for "B" Price Key Molds (Page 42)
- MH2 - Handle for "C" Price Key Molds (Page 42)

Recommended Tools & Accessories:

- CCBRSH1 - Cable Cleaning Brush (Page 40)
- MCBRSH1 - Mold Cleaning Brushes (Page 41)

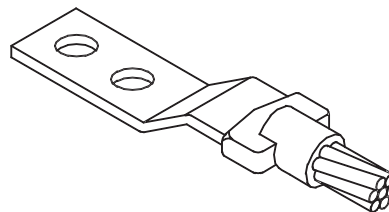

LE

(Lug End)

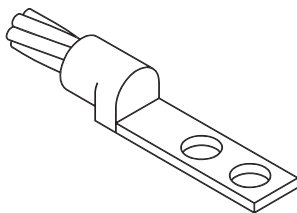

LBJ

(Lug Bent J)

LE Connection Type

Cable Size	Lug Size	Mold Part No.	Weld Metal	
			NUWTube	Ultra-Shot
#6 STR	.125 X 1" LUG	LE6181 B	NUWTUBE45	US45
#4 STR	.125 X 1" LUG	LE4181 B	NUWTUBE45	US45
#2 SOL	.25 X 1" LUG	LE2S141 B	NUWTUBE65	US65
#2 STR	.125 X 1" LUG	LE2181 B	NUWTUBE45	US45
2/0 STR	.25 X 1" LUG	LE2/0141 B	NUWTUBE65	US65
2/0 STR	.125 X 1" LUG	LE2/0181 B	NUWTUBE65	US65
4/0 STR	.25 X 1" LUG	LE4/0141 B	NUWTUBE90	US90
4/0 STR	.25 X 1.5" LUG	LE4/0141.5 B	NUWTUBE90	US90
4/0 STR	.188 X 1" LUG	LE4/03161 B	NUWTUBE90	US90
250 MCM	.25 X 1" LUG	LE25CM141 B	NUWTUBE90	US90
250 MCM	.25 X 1.5" LUG	LE25CM141.5 B	NUWTUBE90	US90
300 MCM	.25 X 1" LUG	LE3CM141 B	NUWTUBE90	US90
300 MCM	.25 X 1.5" LUG	LE5CM141.5 B	NUWTUBE200	US200
300 MCM	.25 X 1.5" LUG	LE3CM141.5 B	NUWTUBE90	US90
500 MCM	.25 X 2" LUG	LE5CM142 B	NUWTUBE200	US200
500 MCM	.375 X 1.5" LUG	LE5CM381.5 B	NUWTUBE200	US200
500 MCM	.375 X 2" LUG	LE5CM382 C	NUWTUBE2X150	US300
750 MCM	.25 X 2" LUG	LE75CM142 C	NUWTUBE2X150	US300
750 MCM	.375 X 1.5" LUG	LE75CM381.5 C	NUWTUBE2X150	US300
750 MCM	.375 X 2" LUG	LE75CM382 C	NUWTUBE2X150	US300
1000 MCM	.375 X 2" LUG	LE1MM382 C	NUWTUBE2X200	US400
1000 MCM	.5 X 2" LUG	LE1MM122 C	NUWTUBE2X250	US500

LBJ Connection Type

Cable Size	Lug Size	Mold Part No.	Weld Metal	
			NUWTube	Ultra-Shot
#6 STR	.125 X 1" J LUG	LBJ6181 B	NUWTUBE32	US32
#4 STR	.125 X 1" J LUG	LBJ4181 B	NUWTUBE32	US32
#2 SOL	.125 X 1" J LUG	LBJ2S181 B	NUWTUBE32	US32
#2 STR	.125 X 1" J LUG	LBJ2181 B	NUWTUBE45	US45
1/0 STR	.125 X 1" J LUG	LBJ1/0181 B	NUWTUBE45	US45
2/0 STR	.125 X 1" J LUG	LBJ2/0181 B	NUWTUBE45	US45
2/0 STR	.188 X 1" J LUG	LBJ2/03161 B	NUWTUBE65	US65
3/0 STR	.125 X 1" J LUG	LBJ3/0181 B	NUWTUBE65	US65
3/0 STR	.188 X 1" J LUG	LBJ3/03161 B	NUWTUBE65	US65
4/0 STR	.125 X 1" J LUG	LBJ4/0181 B	NUWTUBE65	US65
4/0 STR	.188 X 1" J LUG	LBJ4/03161 B	NUWTUBE65	US65

Tinned Copper Lugs - Bent J

Lug Size	Bent J Part No.	Number of Holes	Screw Size	O.C. Dimension	T	W	A	B
1/8 x 1	JXL-1813/8	1	3/8	N/A	1/8	1	1/2	7/8
1/8 x 1	JXL-181	2	3/8	1	1/8	1	5/8	3
1/8 x 1	JXL-1812C1/4	2	1/2	.75"	1/8"	1"	5/8"	3"
1/8 x 1	JXL-1812C3/8	2	1/2	1"	1/8"	1"	5/8"	3"
1/8 x 1	JXL-1812D	2	1/2	1.75"	1/8"	1"	5/8"	3"
3/16 x 1	JXL-3161	1	3/8	N/A	3/16"	1"	9/16"	1-1/8"
3/16 x 1	JXL-31612D	2	3/8	1	3/16"	1"	5/8"	3"

Tinned Copper Lugs - Straight & Offset

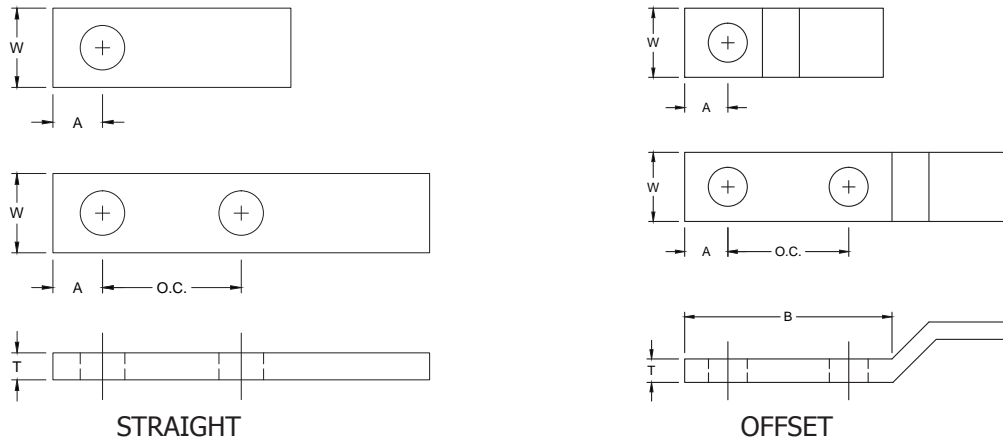

Lug Size	Straight P/N	Offset P/N	Number of Holes	Hole Size	O.C. Dimension	T	W	A	B
1/8 x 1	SXL181	OXL181	1	3/8	N/A	1/8	1	1/2	7/8
1/8 x 1	SXL1812C3/8	OXL1812C3/8	2	3/8	1	1/8	1	5/8	3
1/8 x 1	SXL1812B	OXL1812B	2	1/2	.75"	1/8"	1"	5/8"	3"
1/8 x 1	SXL1812C	OXL1812C	2	1/2	1"	1/8"	1"	5/8"	3"
1/8 x 1	SXL1812D	OXL1812D	2	1/2	1.75"	1/8"	1"	5/8"	3"
3/16 x 1	SXL3161	OXL3161	1	3/8	N/A	3/16"	1"	9/16"	1-1/8"
3/16 x 1	SXL31612C3/8	OXL31612C3/8	2	3/8	1	3/16"	1"	5/8"	3"
3/16 x 1	SXL31612B	OXL31612B	2	1/2	.75	3/16"	1"	5/8"	3"
3/16 x 1	SXL31612C	OXL31612C	2	1/2	1	3/16"	1"	5/8"	3"
3/16 x 1	SXL31612D	OXL31612D	2	1/2	1.75	3/16"	1"	5/8"	3"
1/4 x 1	SXL141	OXL141	1	1/2	N/A	1/4"	1"	5/8"	1-1/8"
1/4 x 1	SXL1412B	OXL1412B	2	1/2	.75	1/4"	1"	5/8"	3"
1/4 x 1	SXL1412C	OXL1412C	2	1/2	1"	1/4"	1"	5/8"	3"
1/4 x 1	SXL1412D	OXL1412D	2	1/2	1.75"	1/4"	1"	5/8"	3"
1/4 x 1-1/2	SXL141.5	OXL141.5	1	5/8	N/A	1/4"	1-1/2"	3/4"	1-1/2"
1/4 x 1-1/2	SXL141.52B	OXL141.52B	2	1/2	.75"	1/4"	1-1/2"	5/8"	3"
1/4 x 1-1/2	SXL141.52C	OXL141.52C	2	1/2	1"	1/4"	1-1/2"	5/8"	3"
1/4 x 1-1/2	SXL141.52D	OXL141.52D	2	1/2	1.75"	1/4"	1-1/2"	5/8"	3"
1/4 x 2	SXL1422B	OXL1422B	2	1/2	.75"	1/4"	2"	5/8"	3"
1/4 x 2	SXL1422C	OXL1422C	2	1/2	1"	1/4"	2"	5/8"	3"
1/4 x 2	SXL1422D	OXL1422D	2	1/2	1.75"	1/4"	2"	5/8"	3"
3/8 x 1-1/2	SXL381.5	OXL381.5	1	5/8	N/A	3/8"	1-1/2"	3/4"	1-1/2"
3/8 x 1-1/2	SXL381.52B	OXL381.52B	2	1/2	.75"	3/8"	1-1/2"	5/8"	3"
3/8 x 1-1/2	SXL381.52C	OXL381.52C	2	1/2	1"	3/8"	1-1/2"	5/8"	3"
3/8 x 1-1/2	SXL381.52D	OXL381.52D	2	1/2	1.75"	3/8"	1-1/2"	5/8"	3"
3/8 x 2	SXL382	OXL382	1	5/8	N/A	3/8"	2"	1"	2-1/8"
3/8 x 2	SXL3822B	OXL3822B	2	1/2	.75	3/8"	2"	5/8"	3"
3/8 x 2	SXL3822C	OXL3822C	2	1/2	1	3/8"	2"	5/8"	3"
3/8 x 2	SXL3822D	OXL3822D	2	1/2	1.75	3/8"	2"	5/8"	3"

For Use with LE Style Molds on Page 34.

Weld Metal



Ultraweld® Molds

- Molds are manufactured from high density, long lasting, semi-permanent graphite. Depending on care and treatment, molds will average over 50 connections, up to 250 when using the UltraShot® system.
- Harger molds are engineered to fit the UltraShot® (electronic ignition system), NUWTube® (traditional ignition system), and Low Smoke-No Flame systems in the same mold. No need for special molds.
- Molds are proudly manufactured in the United States.

UltraShot®

- The UltraShot system uses an electric charge to dependably fire the exothermic welding shot.
- The weld metal, a mixture of copper oxide and aluminum, is packaged in individual, moisture resistant copper drop-ins.
- The copper drop-in is consumed during the reaction process.
- Each drop-in copper container is marked with the size.
- The drop-ins are packaged in a box containing either 5, 10, or 20 units per box. See table to right for carton quantities.

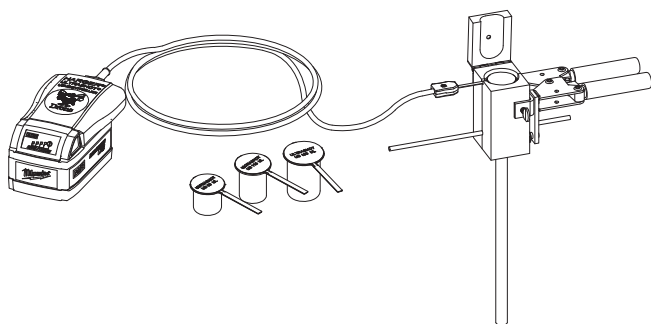

UltraShot® (Drop-In) Weld Metal

UltraShot Size	UltraShot Rail Size	Qty. Per Carton
US25	US25R	20
US32	US32R	20
US45	US45R	20
US65	US65R	20
US90	US90R	10
US115	US115R	10
US150	US150R	10
US200	US200R	10
US250	US250R	10
US300	US300R	10
US400	US400R	5
US500	US500R	5
US600	US600R	5
US750	US750R	5

Materials, Tools, & Accessories

NUWTube®

- The weld metal, a mixture of copper oxide and aluminum, is packaged in individual, moisture resistant plastic tubes.
- Dual chamber design holds starting material and weld metal separately, in the same tube.
- Easy to identify with color coded caps.
- NUWTube - Clear = Weld Metal, Orange = Starting Material.
- Rail NUWTube - Clear = Weld Metal, Grey = Starting Material.
- Each cartridge is marked with the size.
- Each box also contains instructions and metal disks. One metal disk is used for each connection.

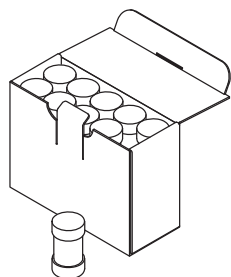

NUWTube® (Pour & Shoot) Weld Metal

NUWTube Size	NUWTube Rail Size	Qty. Per Carton
NUWTUBE25	NUWTUBE25R	20
NUWTUBE32	NUWTUBE32R	20
NUWTUBE45	NUWTUBE45R	20
NUWTUBE65	NUWTUBE65R	20
NUWTUBE90	NUWTUBE90R	10
NUWTUBE115	NUWTUBE115R	10
NUWTUBE150	NUWTUBE150R	10
NUWTUBE200	NUWTUBE200R	10
NUWTUBE250	NUWTUBE250R	10

Low Smoke-No Flame System

Using Harger's unique mold design and patented handle clamp system, any mold that uses a MH1 or MH2 handle can be made into a Low Smoke-No Flame mold. All that is required is the purchase of a USSKIT which includes the Universal Clamp, filter housing, and enough filters to do 10 shots. This system does require the use of the UltraShot® electronic ignition system. There are three different kit sizes determined by the size of the US shot required and price key of the mold.



Low Smoke-No Flame Kits

Part No.	Weld Metal Size	Wt. (lbs.)
USSKIT1	25 thru 115	6
USSKIT2	150 thru 300	6
USSKIT3	400	6

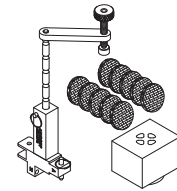

Kit Includes:

- (1) Low Smoke-No Flame Adapter Clamp (USSXADPTR)
- (1) Replacement Filter Housing
- (10) Low Smoke-No Flame Filters

Low Smoke-No Flame Adapter Clamp

Part No.	Qty.	Wt. (lbs.)
USSXADPTR	EACH	3



Low Smoke-No Flame Filters

Part No.	Filter Housing	Wt. (lbs.)
USSXFLR1.8	SAFHB25115	0.5
USSXFLR2	SAFHB150300	0.5
USSXFLR3	SAFHC400	0.5

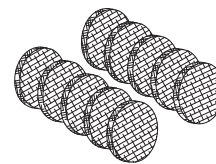

- Sold as 10 pack.

Replacement Filter Housing

Part No.	Weld Metal Size	Wt. (lbs.)
SAFHB25115	25 thru 115	0.5
SAFHB150300	150 thru 300	0.5
SAFHC400	400	0.75

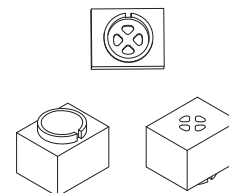

UltraShot Drone

Harger's Handheld DRONE

- Ignites UltraShot® copper drop-in weld metal cartridges that are consumed in the exothermic connection.
- Utilizes a Milwaukee® M18™ REDLITHIUM™ XC 4.0 18 volt battery featuring a built-in fuel gauge, the DRONE makes over 1,300 connections on a single charge!
- The Ultra Bright LED indicates instantaneous ignition. Borrowing from our previous model, the dual trigger ignition design adds an additional safety measure.
- Includes a 6' cord featuring a quick latch disconnect which allows for easy storage.

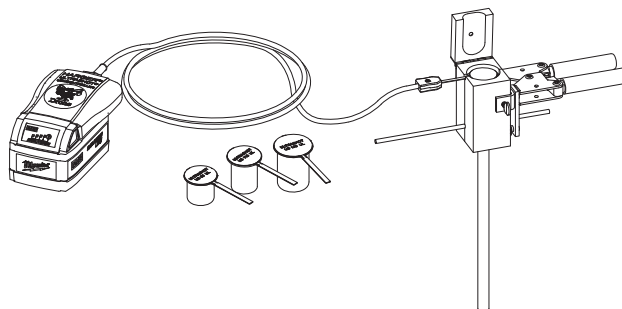

Drone

Part No.	Wt. (lbs.)
DRONE	1

- Does NOT INCLUDE battery.

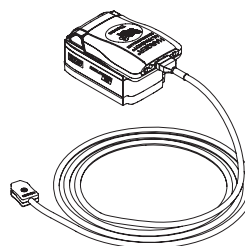

Drone Accessories

Battery

Part No.	Wt. (lbs.)
MIL1840BAT	1.5

- M18™ Battery

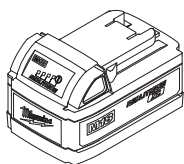

Pouch

Part No.	Wt. (lbs.)
DRONEPOUCH	0.24

- Easily transport the DRONE hands-free from connection to connection

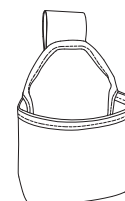

Charger

Part No.	Wt. (lbs.)
MIL1812CHARGER	1.5

- M18™ & M12™ Multi-Voltage



Case

Part No.	Wt. (lbs.)
DRONECASE	3

- Keep organized with this storage option. Holds the Drone, Battery, Charger & Cord.

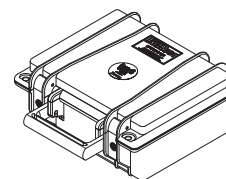

6' Cord

Part No.	Wt. (lbs.)
DRONECORD	1

- Replacement cord

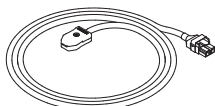

Drone Accessory Kit

Part No.	Wt. (lbs.)
DAK	18

- Includes the Case, Battery & Charger.

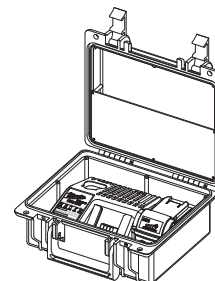

Mold Accessories

Flint Igniter

Part No.	Description	Qty.	Approx. Wt. (lbs.)
FLTIG	Flint Igniter	EACH	0.21
FLTIGEXT	Flint Igniter 36" Extension	EACH	3
RPLFLT	Replacement Flint	EACH	0.01

- When making an Ultraweld connection, Flint Igniters are used to ignite the starting material.
- Flint igniters come with Price Key "A" Molds, MH1 & MH2 handle clamps.
- Replacement Flints are also available.

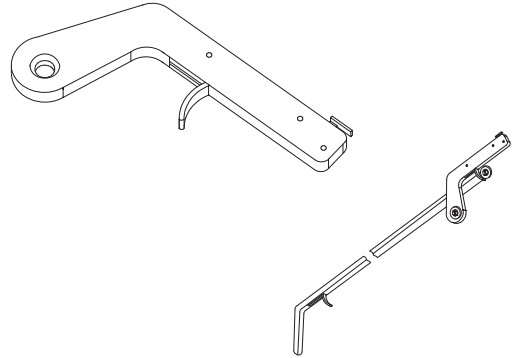

Torch Head

Part No.	Qty.	Approx. Wt. (lbs.)
TRCHD	EACH	2

- Self-igniting Torch Head is designed to fit 14 or 16 ounce propane cylinders.
- Torches are required to remove moisture from the mold and conductors before making the Ultraweld connections.

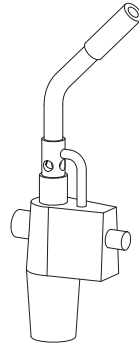

Adapting Molds to Fit Conductors

Wrap Sleeves

Part No.	Qty.	Approx. Wt. (lbs.)
WRPSLV	EACH	0.01

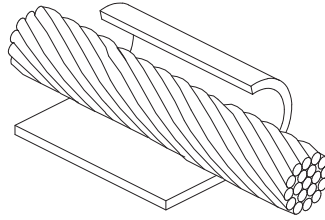

- Wrap Sleeves can be used when welding cables smaller than indicated on mold tag.
- When the cable opening in the mold is larger than the cable, copper Wrap Sleeves are wrapped around the cable until the diameter is about the same size as the mold cable opening.
- A copper Wrap Sleeve is also used for wrapping around rebar for certain connection styles.

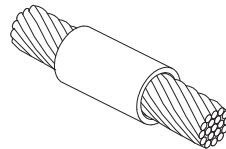

Adapter Sleeves

Part No.	Cable Size		Fits Molds	Sleeve Dimensions			Box Qty.	Approx. Box Wt. (lbs.)
	Concentric Strand	Solid		O.D.	I.D.	Length		
ADPSLV6	#12, 14	#10, 12, 14	#6 Solid	0.156	0.111	1	25	0.25
ADPSLV4	#7, 8, 10	#6, 8	#4 Stranded	0.227	0.177	1	25	0.25
ADPSLV2A	#6	#5	#2 Stranded	0.292	0.198	1	25	0.25
ADPSLV2B	#4, 5	#3, 4	#2 Stranded	0.287	0.246	1	25	0.25
ADPSLV1	#4	n/a	#1 Stranded	0.34	0.246	1	25	0.25
ADPSLV1/0	#2	#1	1/0 Stranded	0.37	0.307	1	25	3
ADPSLV2/0	#1	1/0	2/0 Stranded	0.42	0.359	1	25	0.25
ADPSLV3/0	1/0, 1	2/0	3/0 Stranded	0.45	0.389	1	25	.25
ADPSLV4/0	2/0, 1/0	3/0	4/0 Stranded	0.52	0.437	1	25	0.25

Adapting Molds to Fit Conductors

Ceramic Rebar Packing Material

Part No.	Qty.	Approx. Wt. (lbs.)
CERPM1	25	0.25
CERPM2	25	0.25
CERPM3	25	0.25

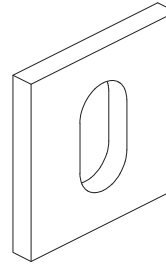

- Packing consists of preformed ceramic batting.
- Packing is required on certain rebar connections to prevent leakage.
- Some connection styles may require wrap sleeves in place of ceramic packing.

Mold Sealer

Part No.	Qty.	Approx. Wt. (lbs.)
MLDSLRL	EACH	2

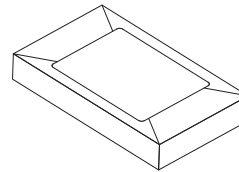

- Mold Sealer is for sealing slightly worn molds to guard against leakage from large stranded conductors or where mold requires it.
- Available in a convenient 1 pound package.

Cable & Work Surface Preparation

Cold Galvanizing Spray

Part No.	Qty.	Net Contents
CGS	EACH	0.88



- Instant cold galvanizing spray provides protection equal to hot dip galvanizing.
- Used for touching up surfaces affected by welding.

Rasp

Part No.	Qty.	Approx. Wt. (lbs.)
RASP	EACH	3



- Ideal for removing mill scale and rust from steel surfaces.

Cable Cleaning Brush

Part No.	Qty.	Approx. Wt. (lbs.)
CCBRSH1	1	0.11

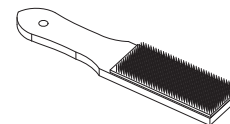

- The Cable Cleaning Brush has short, stiff, metal bristles which are generally preferred for cleaning concentric conductors and busbars, that are not heavily oxidized.

Cable Cleaning Brush - Heavy Duty

Part No.	Qty.	Approx. Wt. (lbs.)
CCBRSH2	1	1.50
CCBRSH2R	1	0.25

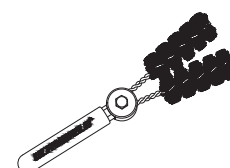

- Ideal for cleaning concentric stranded cable, especially very dirty or oxidized conductors.

Mold Care & Use

Mold Cleaning Brushes

Part No.	Qty.	Approx. Wt. (lbs.)
MCBRSH1	1	0.11
MCBRSH2	1	0.05

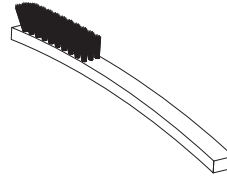

- Slag can be removed from molds by using a Mold Cleaning Brush.
- The brush is especially useful on vertical split molds.
- Consistent and proper use of the brush will aid in maintaining or exceeding the average mold life of 50 connections.

Mold Cleaning Spades

Part No.	Weld Metal Sizes	Qty.	Approx. Wt. (lbs.)
MCSPD25/115	25 - 115	1	0.21
MCSPD150/400	150 and larger	1	0.26

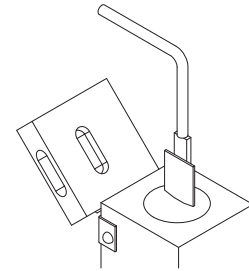

- Slag can be cleaned from the molds by using a Mold Cleaning Spade.
- The cleaning spade is especially useful on horizontally split molds.
- The cleaning spades are specifically designed to fit the mold crucible for a given range of weld metal sizes.
- Consistent and proper use of cleaning spades will aid in maintaining or exceeding the average mold life of 50 connections.

Disks

Part No.	Description	Diameter	Box Qty.	Approx. Box Wt. (lbs.)
DISK15/65	Used in molds using 15 thru 65 weld metal	3/4"	20	0.6
DISK90/115	Used in molds using 90 thru 115 weld metal	1"	10	0.3
DISK150/500	Used in molds using 150 thru 250 weld metal	1-1/2"	10	0.6

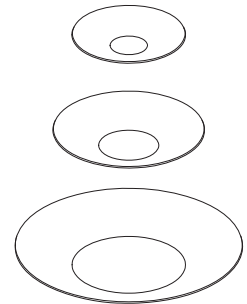

- The disk rests on the bottom of the crucible and holds the weld metal powder in place until the reaction occurs.
- Disks are only used in the NUWTube system.
- A new disk is required each time a weld is made with NUWTube system.
- Disks are included with the NUWTUBE Weld Metal.

Disk Kit

Part No.	Qty.	Approx. Wt. (lbs.)
DISKKIT1	1	0.37

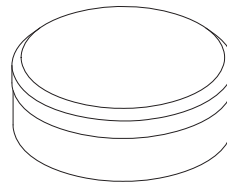

- A Disk Kit contains three sizes of steel disks; 60 small, 30 medium and 30 large.

Mold Blanket

Part No.	Qty.	Approx. Wt. (lbs.)
ULTRAWRAP	EACH	2

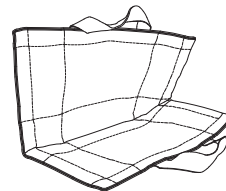

- Contains an inner and outer E-glass yarn with a padded non-crystalline silicate filling, finished with Kevlar®.
- Extends mold life by protecting against shock impact caused by rough handling.
- Protects exothermic welders from coming into contact with hot molds.
- Used as a protection blanket against weld splatter.

Mold Fastening & Mounting

Mold Handle Clamp

Part No.	Application	Qty.	Approx. Wt. (lbs.)
MH1	For All molds with B, E, K, P & Q mold price key (3" wide)	1	3.05
MH2	For All molds with C, D, F, Y & Z mold price key (4" wide)	1	3.63
MH3	For all L & M mold price key	1	0.65

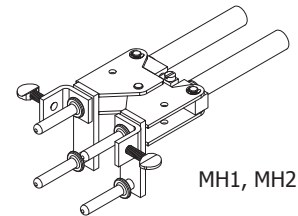

- MH3 Mold Handle Clamps are included with L & M molds.
- Some molds are used with specialized frames.
- Handle clamps MH1 & MH2 come with a flint igniter (FLTIG).
- Handle clamps have a Zinc plated finish.

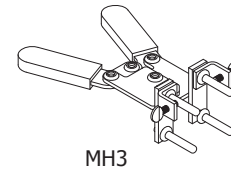

Chain Support Handle Clamp

Part No.	Fits Mold Price Key	For Following Connection Types	Pipe/Rebar	Qty.	Approx. Wt. (lbs.)
CSH1	B, E, K	RE, VA, VD, VT, VU	Vertical	1	5
CSH2	C, D, F	VA, VD, VT, VU	Vertical	1	5

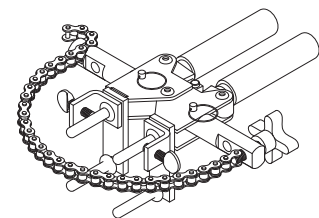

- Handle clamps CSH1 & CSH2 come with MH1 & MH2 clamps respectively as well as a CSKIT and flint igniter (FLTIG).
- Chain Support Handle Clamps are used to securely hold the mold to either a vertical or horizontal pipe.
- A 20" length of chain, which fits up to 4" pipes, comes with the chain support handle clamps.
- Extra chain length is available. Please contact factory for details.

Chain Support Kits

Part No.	Fits Mold Price Key	For Following Connection Types	Pipe/Rebar	Qty.	Approx. Wt. (lbs.)
CSKIT	B, C, D, E, F, K	RE, VA, VD, VT, VU	Vertical	1	1
CSKITHSVM	B, C	VH, RS	Vertical	1	2
CSKITHP	B, C	HB, HD, HT, HU	Horizontal	1	2
CSKITHPVS	B	HTCP, RO	Horizontal	1	2



- These kits convert standard mold handle clamps into chain support clamps.

Magnetic Support Handle Clamp

Part No.	Fits Mold Price Key	Minimum Width Requirements	Qty.	Approx. Wt. (lbs.)
MSHC1	B, E, K	8"	1	6
MSHC2	C, D, F	8"	1	7

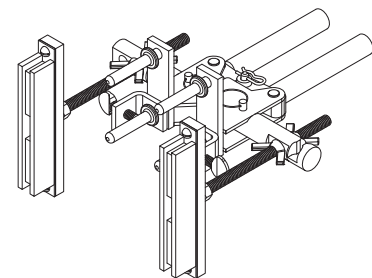

- Handle clamps MSHC1 & MSHC2 come with MH1 & MH2 clamps respectively as well as a MSKIT and a flint igniter (FLTIG).
- Magnetic Support Handle Clamp allows mold to be securely held in place to steel surfaces.

Magnetic Support Kit

Part No.	Fits Mold Price Key	Minimum Width Requirements	Qty.	Approx. Wt. (lbs.)
MSKIT	B, C, D, E, F, K	8"	1	3
MSKITHSVS	B, C, D, K	10"	1	5



- These kits convert the standard mold handle clamp into a magnetic support handle clamp.

Mold Fastening & Mounting continued

Hold Down Kit

Part No.	Qty.	Approx. Wt. (lbs.)
UMHDKIT	EACH	1.5
UMMHDA	EACH	0.5

- UMHDKIT: Attaches easily to MH1 & MH2 handle clamp for holding mold in place.
- UMMHDA: Used for horizontal "A" molds.

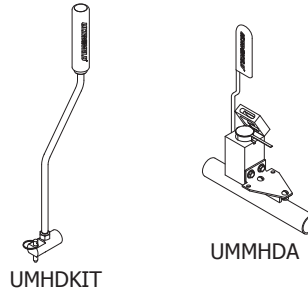

Mold Stabilizer Kit

Part No.	Qty.	Approx. Wt. (lbs.)
MLDSTBLZR	EACH	0.55

- Used to stabilize mold when making cable to cable welds in a trench.
- 6" or 12" spikes can be used depending on soil conditions.

Kit includes:

- 2 ea. 6" Spikes,
- 2 ea. 12" Spikes
- 2 ea. Spike Mounting Adaptors
- 2 ea. Pins

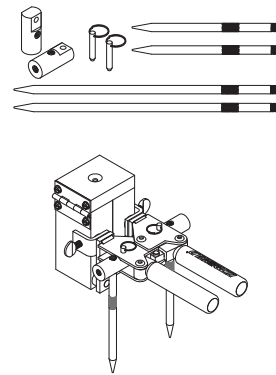

Conductor Identification

Bare Class A, B, and C Concentric Stranded Conductors Based on A.S.T.M Standard Specifications

Size in Circular mils	Size A.W.G.	Conductor Diameter	Number of Wires					Cable Code
			7	19	37	61	91	
1,000,000	1000	1.152"			.1644*	.1280	.0148	1MM
800,000	800	1.031"		.1470*	.1145	.0938		8CM
750,000	750	.998"		.1424*	.1109	.0908		75CM
700,000	700	.964"		.1375*	.1071	.0877		7CM
600,000	600	.893"		.1273	.0992	.0812		6CM
500,000	500	.813"		.1622*	.1162	.0905		5CM
400,000	400	.728"		.1451	.1040	.0810		4CM
350,000	350	.681"		.1357	.0973	.0757		35CM
300,000	300	.630"		.1257	.0900	.0701		3CM
250,000	250	.575"		.1147	.0822	.0640		25CM
211,600	4/0	.528"	.1739	.1055	.0756			4/0
167,800	3/0	.470"	.1548	.0940	.0763			3/0
133,100	2/0	.419"	.1379	.0837	.0600			2/0
105,500	1/0	.373"	.1228	.0745	.0534			1/0
83,690	1	.332"	.1093	.0664	.0467			1
66,370	2	.292"	.0974	.0591				2
52,630	3	.260"	.0867	.0526				3
41,740	4	.232"	.0772	.0469				4
26,240	6	.184"	.0612	.0372				6
16,510	8	.146"	.0486	.0295				8
10,380	10	.116"	.0385	.0234				10
6,530	12	.0915"	.0305	.0185				12
4,110	14	.0726"	.0242	.0417				14

* Class AA

Technical Information

Bare Solid Copper Conductors Based on A.S.T.M Standard Specifications

Size A.W.G.	Cross Sectional Area Circular Mils	Wire Diameter	Cable Code
4/0	211,600	.4600"	4/0S
3/0	167,800	.4096"	3/0S
2/0	133,100	.3648"	2/0S
1/0	105,500	.3249"	1/0S
1	83,690	.2893"	1S
2	66,370	.2576"	2S
3	52,630	.2294"	3S
4	41,740	.2043"	4S
6	26,250	.1620"	6S
8	16,510	.1285"	8S
10	10,380	.1019"	10S
12	6,530	.0808"	12S
14	4,110	.0641"	14S

Conductor Area Conversions

Square Inches x 1273 = MCM
MCM x 7.862 x 10⁻⁴ = Square Inches

Square Inches x 645.2 = Square Millimeter
Square Millimeter x 1.550 x 10⁻³ = Square Inches

Square Millimeters x 1.9736 = MCM
MCM x 0.5067 = Square Millimeters

1 MCM = 1 kcmil = 1,000 circular mil

Copper-Clad Steel Conductors

Cable Stranding	Nominal Diameter (in.)	Cross Sectional Area (kcmil)	Cable Code
3/#10 CW	.220	31.15	3/10CW
3/#9 CW	.247	39.28	3/9CW
3/#8 CW	.277	49.53	3/8CW
7/#10 CW	.306	72.68	7/10CW
3/#7 CW	.311	62.45	3/7CW
7/#9 CW	.343	91.65	7/9CW
3/#6 CW	.349	78.75	3/6CW
7/#8 CW	.385	115.60	7/8CW
3/#5 CW	.392	99.31	3/5CW
7/#7 CW	.433	145.70	7/7CW
7/#6 CW	.486	183.80	7/6CW
7/#5 CW	.546	231.63	7/5CW
19/#9 CW	.572	248.70	19/9CW
7/#4 CW	.613	292.20	7/4CW
19/#8 CW	.642	313.70	19/8CW
19/#7 CW	.721	395.60	19/7CW
19/#6 CW	.810	498.60	19/6CW
19/#5 CW	.910	628.70	19/5CW

Ground Rods

Nominal Size	Material	Type	Body Diameter	Thread Size	Ground Rod Code
1/2"	Copper-clad	Sectional	.500"	9/16"	12S
1/2"	Copper-clad	Plain	.500"	N/A	12
1/2"	Steel*	Plain	.500"	N/A	12F
1/2"	Copper-clad	Plain	.475"	N/A	12
5/8"	Steel*	Plain	.625"	N/A	58F
5/8"	Copper-clad	Plain	.563"	N/A	58
5/8"	Copper-clad	Sectional	.563"	5/8"	58S**
3/4"	Steel*	Plain	.750"	N/A	34F
3/4"	Copper-clad	Plain	.682"	N/A	34
3/4"	Copper-clad	Sectional	.682"	3/4"	34S**
1"	Steel*	Plain	1.000"	N/A	10F
1"	Copper-clad	Plain	.914"	N/A	10
1"	Copper-clad	Sectional	.914"	1"	10S**

* Plain steel, stainless steel, stainless clad rods or galvanized steel.

** Add S to sectional ground rod size for connections to end of rod such as:
GD, GF, GO, GT, GG

Stranded Copper Conductor

Concentric Lay Soft-Drawn Bare Copper

Part No.	Size (AWG)	No. of Strands	CM Area	Approx. Wt. lbs./M ft.
8-7	8	7	16,510	51
6-7	6	7	24,240	81
4-7	4	7	41,740	127
2-7	2	7	66,360	204
1/0-19	1/0	19	105,600	325
2/0-7	2/0	7	133,100	410
2/0-19	2/0	19	133,100	410

- Contact factory for reel sizes/put ups.

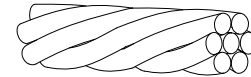

7 Strand Concentric

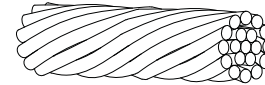

19 Strand Concentric

Green Insulated Conductor

Part No.	Size (AWG)	No. of Strands	Jacket Type	CM Area	Approx. Wt. lbs./M ft.
67G	6	7	THW	26,240	105
6-19G	6	19	THHN	26,240	98
47G	4	7	THW	41,740	160
4-19G	4	19	THHN	41,740	157
27G	2	7	THW	66,360	245
2-19G	2	19	THHN	66,360	240
1/019G	1/0	19	THHN	105,600	372
2/019G	2/0	19	THHN	133,100	462

- Contact factory for reel sizes/put ups.



19 Strand Insulated

NOTES:

- Green Insulated conductor carries a THW or THHN rating. Other colors available upon request.
- Sizes up to 1000 MCM are available. Please contact the factory for special requests.
- Harger offers standard reel sizes, however we will cut to specified lengths.
- Bare Stranded conductor shall meet the requirements of ASTM B-8.
- Stranded copper conductors available tinned. Please add suffix "T" to part number.

Solid Copper Conductor

Solid Single Soft-Drawn Bare Copper

Part No.	Size (AWG)	Diameter	CM Area	Approx. Wt. lbs./Reel
10	10	.101	10,380	31-1/2
8	8	.128	16,510	50
6	6	.162	26,240	80
4	4	.204	41,470	126
2	2	.257	66,360	201

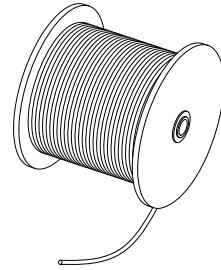

Solid Tinned Copper Conductor

Solid Single Soft-Drawn Bare Tinned Copper

Part No.	Size (AWG)	Diameter	CM Area	Approx. Wt. lbs./Reel
8T	8	.128	16,510	50
6T	6	.162	26,240	80
4T	4	.204	41,470	126
2T	2	.257	66,360	201

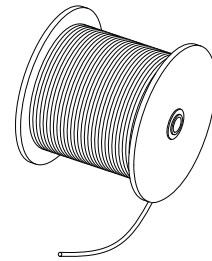

- 2T can be ordered as stock items #2T-250 (250' standard reel) and #2T-500 (500' standard reel).
- Contact factory for reel sizes/put ups.

NOTES:

- Other sizes are available. Please contact factory for special requests.
- Solid soft-drawn conductors shall meet the requirements of ASTM B-3.
- Tinned Copper conductors shall meet the requirements of ASTM B-33.

Copper Clad Steel Ground Rod

Part No.	Size	Approx. Wt. (lbs.)	Standard Bundle	Approx Wt. lbs./Bundle	UL Mark	With UPC Label
1208UPC	1/2" x 8'	6	5	30	Yes	Yes
1210	1/2" x 10'	7	5	35	Yes	No
588	5/8" x 8'	6	5	30	Yes	No
588RUS	5/8" x 8'	7	5	35	Yes	No
588UPC	5/8" x 8'	7	5	35	Yes	Yes
5810	5/8" x 10'	9	5	45	Yes	No
5810UPC	5/8" x 10'	9	5	45	Yes	Yes
348	3/4" x 8'	11	5	55	Yes	No
3410	3/4" x 10'	13	5	65	Yes	No
3412	3/4" x 12'	15	5	75	Yes	No
110	1" x 10'	23	3	69	Yes	No

- For more information refer to Ground Rod table on page 45.

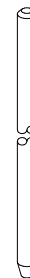

Stainless Steel Ground Rod

Part No.	Size	Approx. Wt. (lbs.)	Standard Bundle	Approx Wt. lbs./Bundle	UL Mark
1210SS3	1/2" x 10'	7	5	35	Yes
588SS3	5/8" x 8'	9	5	45	Yes
5810SS3	5/8" x 10'	11	5	55	Yes
3410SS3	3/4" x 10'	15	5	75	Yes

- All rods are full diameter.
- Made from Solid 304 Stainless Steel.
- For more information refer to Ground Rod table on page 45.

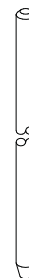

Galvanized Steel Ground Rod

Part No.	Size	Approx. Wt. (lbs.)	Standard Bundle	Approx Wt. lbs./Bundle	With UPC Label
126G	1/2" x 6'	4	5	20	No
126GUPC	1/2" x 6'	4	5	20	Yes
128G	1/2" x 8'	6	5	30	No
128GUPC	1/2" x 8'	6	5	30	Yes
3410G	3/4" x 10'	15	5	75	No
348G	3/4" x 8'	12	5	60	No
5810G	5/8" x 10'	10	5	50	No
5810GUPC	5/8" x 10'	5	50	55	Yes
588G	5/8" x 8'	8	5	40	No
588GUPC	5/8" x 8'	8	5	40	Yes

- All rods are full diameter.

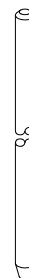

NOTES:

- Manufactured from zinc coated high strength steel.
- Meets requirements of NEMA GR-1.
- Preferred electrode when primary concern is cathodic protection to structure.
- Non UL listed.

Ground Rod Driver

Part No.	Description	Ground Rod Size	Qty.	Approx. Wt. (lbs.)
GRD34I	3/4 Replacement Insert	3/4"	EACH	12
GRD58	5/8 Ground Rod Driver & Insert	1/2" & 5/8"	EACH	25

- Drives ground rods from ground level without the need for a ladder or sledge hammer.
- 3/4" insert is interchangeable with driver body.
- Insert prevents driver from slipping off ground rod near ground level.
- Insert prevents "mushrooming" top of ground rod.

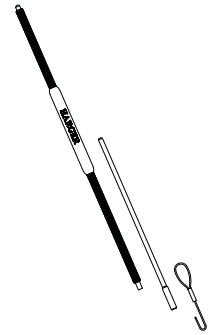

Ground Rod Drivers

Part No.	Description	Qty.	Approx. Wt. (lbs.)
SMGRD58U	5/8" Ground Rod Driver	1	16
SMGRD58USHGR	5/8" Ground Rod Driver	1	14

- SMGRD58U - Ground rod driver with slide hammer. One end is threaded for use with threaded 5/8" ground rods and the other end is for use with tapered 5/8" copper clad steel ground rods.
- SMGRD58USHGR - Ground rod driver with slide hammer, connects to ground rods with 5/8" threads on both ends.
- Used to install or remove threaded ground rods.

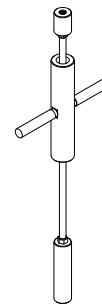

Drive Sleeves

Part No.	Ground Rod Size	Qty.	Approx. Wt. (lbs.)
GRD58	5/8"	1	1
GRD34	3/4"	1	1

- For Copper Clad Steel ground rods.
- Prevents "mushrooming" top of ground rod while driving ground rod.

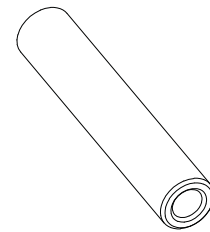

Drive Studs

Part No.	Ground Rod Size	Box Qty.	Approx. Box Wt. (lbs.)
GDS12	1/2"	5	1
GDS58	5/8"	5	1
GDS34	3/4"	5	3
GDS1	1"	3	2

- High strength alloy driving stud prevents damage to the coupler or ground rod threads when driving ground rods.

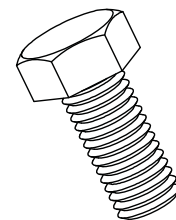

Flexible Gate Jumpers

Part No.	Jumper Size	Conductor Size (AWG)	Approx. Wt. (lbs.)	Box Qty.	Approx. Box Wt. (lbs.)
GJX2S24	#2 AWG	#2 solid	1/2	10	5
GJX2/024	2/0 AWG	2/0 concentric	1	10	10
GJX4/024	4/0 AWG	4/0 concentric	1-1/2	10	15

- Can be used with the universal pipe clamps or can be exothermically welded to the fence/gate post.
- Three sizes designed to fit either a #2 solid, 2/0 stranded or 4/0 stranded exothermic mold.
- Flex jumpers made from welding cable.
- Standard length is 24" long.
- Other lengths available. Please contact factory for more information.

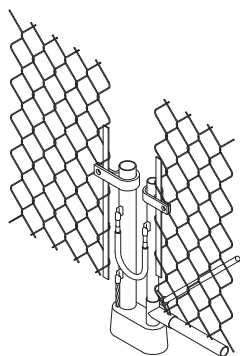
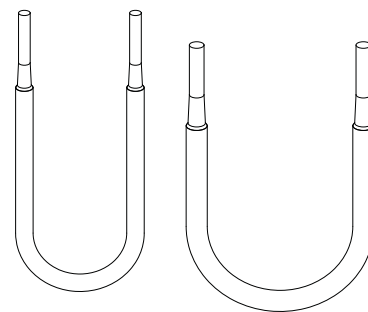

VDRFP Connection Type (Range Taking)

Cable Size	Nominal Pipe Size	Mold Part No.	Weld Metal	
			NUWTube	UltraShot
#2 Sol	1-1/4" to 4" Round Fence Post	VDRFP2SB	NUWTUBE65	US65
2/0	1-1/4" to 4" Round Fence Post	VDRFP2/0B	NUWTUBE115	US90
4/0	1-1/4" to 4" Round Fence Post	VDRFP4/0B	NUWTUBE150	US115

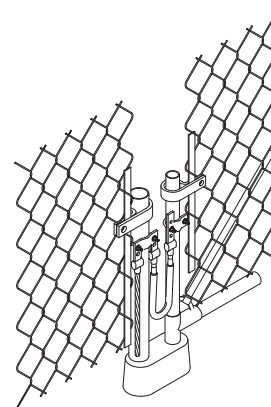

LE Connection Type

Cable Size	Lug Size	Mold Part No.	Weld Metal	
			NUWTube	UltraShot
#2 Sol	1/4" x 1"	LE2S141B	NUWTUBE65	US65
2/0	1/4" x 1"	LE2/0141B	NUWTUBE65	US65
4/0	1/4" x 1"	LE4/0141B	NUWTUBE90	US90

NOTES:

Thin walled pipe may be unsuitable for exothermic connections. If experiencing burn through issues with the pipe (typically with 2/0 or 4/0 conductors), adding sand inside the fence post well past the exothermic connection may solve this problem. Another solution would be to use a smaller conductor such as a #2 AWG jumper which uses a smaller size weld metal. The last solution may be to use mechanical fence clamp. (Contact the factory for more information.)

Universal Pipe Clamps

Part No.	Material	Nominal Pipe Size	Box Qty.	Approx. Box Wt. (lbs.)
UPC.75/1.25	Tinned Copper	.75" - 1.25"	10	9
UPC1.5/2	Tinned Copper	1.5" - 2"	10	13
UPC2.5/3	Tinned Copper	2.5" - 3"	5	6
UPC3.5/4	Tinned Copper	3.5" - 4"	5	7
UPC5/6	Tinned Copper	5" - 6"	5	9

- All clamps provide a minimum of 1-1/2" of contact area to ensure sufficient electrical contact for both ground fault and lightning current.
- These clamps can be connected to ground conductors via exothermic connections and/or standard compression lugs.
- Lug ends are 1/4" x 1" and have holes that are 3/8" diameter 1" on center spacing.
- The UPC.75/1.25 provides bi-directional grounding capabilities making it the perfect connection for grounding fence rail to fence post applications.
- All clamps are manufactured from highly conductive tinned copper and feature stainless steel hardware.

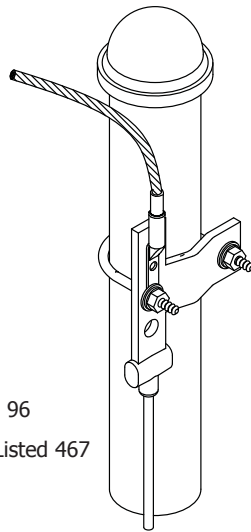
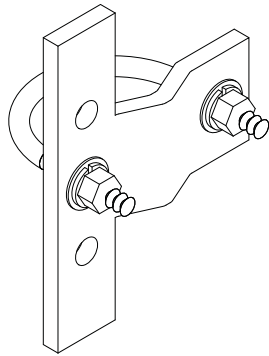

UL Listed 96
UL Listed 467

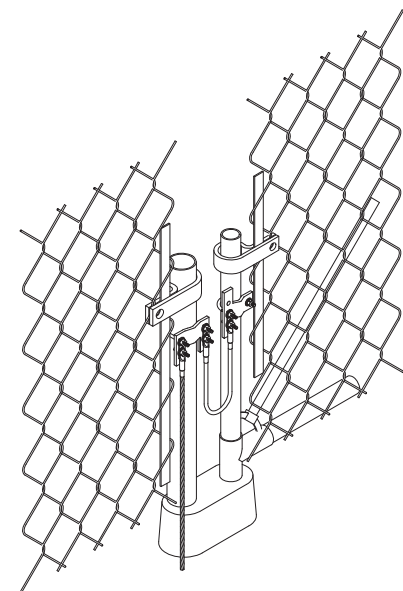
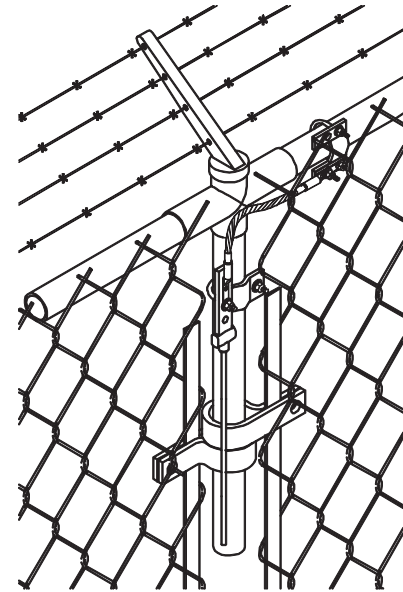
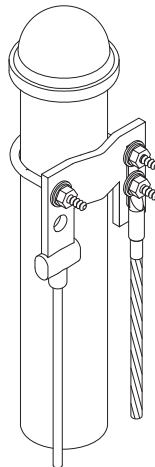
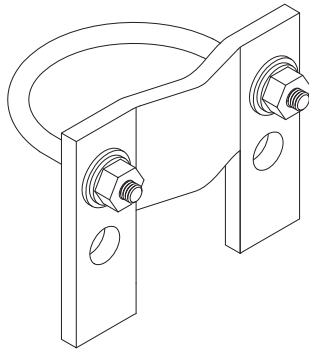

LE Connection Type

Cable Size	Lug Size	Mold Part No.	Weld Metal	
			NUWTube	UltraShot
#2 Sol	1/4" x 1"	LE2S141B	NUWTUBE65	US65
2/0	1/4" x 1"	LE2/0141B	NUWTUBE65	US65
4/0	1/4" x 1"	LE4/0141B	NUWTUBE90	US90

One Hole, Standard Barrel, Compression Lugs

Part No.	Conductor Size (AWG)	Hardware Size	Color Code	Box Qty.	Approx. Box Wt. (lbs.)
GECL6	6	1/4"	Blue	50	0.5
GECL63/8	6	3/8"	Blue	50	1
GECL4	4	1/4"	Gray	50	1
GECL43/8	4	3/8"	Gray	50	1
GECL21/4	2	1/4"	Brown	50	2
GECL2	2	5/16"	Brown	50	2
GECL23/8	2	3/8"	Brown	50	2
GECL1/0	1/0	3/8"	Pink	10	0.5
GECL2/0	2/0	3/8"	Black	10	0.6
GECL4/0	4/0	1/2"	Purple	10	1
GECL250	250	1/2"	Yellow	10	1
GECL500	500	1/2"	Brown	10	3.5



Listed 486

- Manufactured from electro plated tinned copper.
- For use on copper or tinned copper conductors.
- Lugs have inspection ports.
- Other sizes available. Please contact factory for more information.

One Hole, Long Barrel, Compression Lugs

Part No.	Conductor Size (AWG)	Hardware Size	Inspection Port	Color Code	Box Qty.	Approx. Box Wt. (lbs.)
GECLB8NP	8	1/4"	No	Blue	50	1
GECLB83/8NP	8	3/8"	No	Blue	50	1
GECLB6	6	1/4"	Yes	Blue	50	1
GECLB63/8	6	3/8"	Yes	Blue	50	3
GECLB6NP	6	1/4"	No	Gray	50	2
GECLB63/8NP	6	3/8"	No	Gray	50	1
GECLB4	4	1/4"	Yes	Gray	50	2
GECLB43/8	4	3/8"	Yes	Gray	50	2
GECLB21/4	2	1/4"	Yes	Brown	50	2
GECLB21/4NP	2	1/4"	No	Brown	50	
GECLB2	2	5/16"	Yes	Brown	50	3
GECLB23/8	2	3/8"	Yes	Brown	50	2
GECLB23/8NP	2	3/8"	No	Brown	50	3
GECLB1/0	1/0	3/8"	Yes	Pink	10	1
GECLB2/0	2/0	3/8"	Yes	Black	10	2
GECLB4/0	4/0	1/2"	Yes	Purple	10	3
GECLB250	250	1/2"	Yes	Yellow	10	3
GECLB500	500	1/2"	Yes	Brown	10	5



GECL6

Listed 486

GECLB83/8NP

"NP" at end of part number indicates NO inspection port

- Manufactured from electro plated tinned copper.
- For use on copper or tinned copper conductors.
- Lugs have inspection ports.
- Other sizes available. Please contact factory for more information.

Two Hole, Long Barrel, Compression Lugs



Part No.	Conductor Size (AWG)	O.C. Dim. B/T Holes	Hardware Size	Inspection Port	Color Code	Box Qty.	Approx. Box Wt. (lbs.)
GECLB82ANP	8	.625"	1/4"	No	Red	50	2
GECLB82CNP	6	.75"	3/8"	No	Red	50	2
GECLB62A	6	.625	1/4"	Yes	Blue	50	2
GECLB62ANP	6	.625	1/4"	No	Blue	50	2
GECLB62B	6	.75"	3/8"	Yes	Blue	50	2
GECLB62C	6	1"	3/8"	Yes	Blue	50	2
GECLB62CNP	6	1"	3/8"	No	Blue	50	2
GECLB42A	4	.625"	1/4"	No	Grey	25	1
GECLB42B	4	.75"	1/4"	Yes	Grey	25	1
GECLB42C	4	1"	3/8"	Yes	Grey	25	1
GECLB22BS	2 Sol.	.75"	3/8"	Yes	White	25	2
GECLB22CS	2 Sol.	1"	3/8"	Yes	White	25	2
GECLB22CSNP	2 Sol.	1"	3/8"	No	White	25	1
GECLB22A	2	.625"	1/4"	No	Brown	25	1
GECLB22B	2	.75"	3/8"	Yes	Brown	25	1
GECLB22C	2	1"	3/8"	Yes	Brown	25	2
GECLB22CNP	2	1"	3/8"	No	Brown	25	2
GECLB1/02C	1/0	1"	3/8"	Yes	Pink	10	1
GECLB1/02D	1/0	1.75"	1/2"	Yes	Pink	10	1
GECLB2/02C	2/0	1"	3/8"	Yes	Black	10	1
GECLB2/02D	2/0	1.75"	1/2"	Yes	Black	10	1
GECLB3/02C	3/0	1"	3/8"	Yes	Orange	10	3
GECLB4/02C	4/0	1"	3/8"	Yes	Purple	10	2
GECLB4/02D	4/0	1.75"	1/2"	Yes	Purple	10	2
GECLB2502C	250	1"	3/8"	Yes	Yellow	10	3
GECLB2502D	250	1.75"	1/2"	Yes	Yellow	10	3
GECLB5002C	500	1"	3/8"	Yes	Brown	10	5
GECLB5002D	500	1.75"	1/2"	Yes	Brown	10	3
GECLB7502C	750	1"	3/8"	Yes	Black	10	10
GECLB7502D	750	1.75"	1/2"	Yes	Black	10	11

- Manufactured from electro plated tinned copper.
- For use on copper or tinned copper conductors.
- Lugs have inspection ports.
- Other sizes available. Please contact factory for more information.
- For copper exothermic lugs (See Page 35 - SXL & OXL)

Two Hole, Slotted, Long Barrel, Compression Lugs

Part No.	Conductor Size (AWG)	Hole Spacing Range	Hardware Size	Inspection Port	Color Codes	Box Qty.	Approx. Box Wt. (lbs.)
GECLB62BC	6	.75" to 1"	3/8"	Yes	Blue	50	2
GECLB62BC250BK	6	.75" to 1"	3/8"	Yes	Blue	250	10
GECLB22BCS	2 Sol.	.75" to 1"	3/8"	Yes	White	50	2
GECLB22BC250BK	2 Sol.	.75" to 1"	3/8"	Yes	White	250	17
GECLB22BCSNP	2 Sol.	.75" to 1"	3/8"	No	White	25	1
GECLB22BC	2	.75" to 1"	3/8"	Yes	Brown	50	2
GECLB22BCS250BK	2	.75" to 1"	3/8"	Yes	Brown	250	14



Listed 486

- Manufactured from electro plated tinned copper.
- For use on copper or tinned copper conductors.
- 250 pack comes in one gallon bucket.

Long Barrel Butt Splices

Part No.	Conductor Size (AWG)	Box Qty.	Approx. Box Wt. (lbs.)
CLBBS8	8	50	2
CLBBS6	6	50	2
CLBBS4	4	50	2
CLBB2S	2 Sol.	50	2
CLBBS2	2	50	2
CLBBS2/0	2/0	10	2
CLBBS4/0	4/0	10	2
CLBBS250	250	10	2
CLBBS500	500	10	2



C-Type Compression Taps

Heavy Duty C-Taps

Part No.	Conductor (AWG)		Die Index	Box Qty.	Approx. Box Wt. (lbs.)
	Run	Tap			
CT4666	#4 Stranded #6 Solid	#6 Stranded #6 Solid	BG	50	2
CT4446	#4 Stranded #6 Solid	#4 Stranded #4 Solid	BG	50	2
CT2248	#2 Stranded #2 Solid	#4 Stranded #8 Solid	C	50	4
CT2222	#2 Stranded #2 Solid	#2 Stranded #2 Solid	C	50	4
CT22/0	2/0 Stranded 1/0 Solid	#2 Stranded #8 Solid	O	10	2
CT24/0	4/0 Stranded 3/0 Solid	#2 Stranded #6 Solid	D3	10	4
CT2/02/0	2/0 Stranded 1/0 Solid	2/0 Stranded 1/0 Solid	O	10	2
CT4/02/0	4/0 Stranded 3/0 Solid	2/0 Stranded 1/0 Solid	D3	10	3
CT4/04/0	4/0 Stranded 3/0 Solid	4/0 Stranded 3/0 Solid	D3	10	3

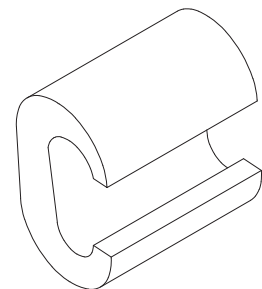

Listed 486

Mechanical Compression Tools



Part No.	Length	Approx. Wt. (lbs.)
MCT	24	6

- Dieless adjustable compression tool with steel handle.
- Works with copper conductor sizes #8 AWG through 250 MCM and aluminum conductors #8 AWG through 4/0.
- For use with compression lugs and light duty compression taps.
- Approximately 2 tons of force.

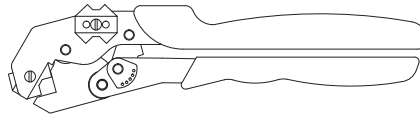

Part No.	Length	Approx. Wt. (lbs.)
MCT81/0	10.5	2

- Handy compression tool terminates copper compression connectors in wire sizes #8 AWG through 1/0.
- Handle length facilitates two-handed crimps when necessary.
- Approximately 2 tons of force.
- Dies included.

CPC & APC Pipe Clamps

Pipe Range .5/.75

Part No.	Material	Nominal Pipe Size Range	Pipe Outside Diameter	Box Qty.	Approx. Box Wt. (lbs.)
CPC.5/.75	ETPB*	.5" - .75"	.375" - 1"	5	2

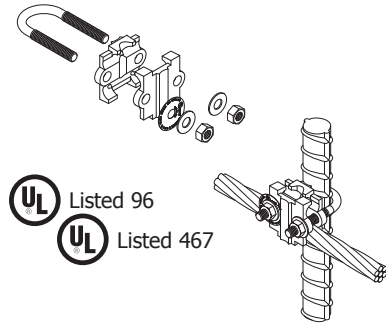

UL Listed 96
UL Listed 467

Pipe Range 1/1.25

Part No.	Material	Nominal Pipe Size Range	Pipe Outside Diameter	Box Qty.	Approx. Box Wt. (lbs.)
CPC1/1.25	ETPB*	1" - 1.25"	.75" - 1.7"	5	4
APC1/1.25	Aluminum	1" - 1.25"	.75" - 1.7"	5	2

- Feature "quick connect", bi-directional design.
- Pressed stud design ensures a flush mounting surface.

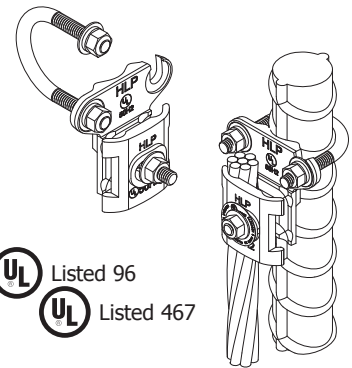

UL Listed 96
UL Listed 467

Pipe Range 1.5/2 - 5/6

Part No.	Material	Nominal Pipe Size Range	Pipe Outside Diameter	Box Qty.	Approx. Box Wt. (lbs.)
CPC1.5/2	ETPB*	1.5" - 2"	1" - 2.4"	5	4
APC1.5/2	Aluminum	1.5" - 2"	1" - 2.4"	5	2
CPC2.5/3	ETPB*	2.5" - 3"	2.25" - 3.5"	5	5
APC2.5/3	Aluminum	2.5" - 3"	2.25" - 3.5"	5	2
CPC3.5/4	ETPB*	3.5" - 4"	3.2" - 4.5"	5	6
APC3.5/4	Aluminum	3.5" - 4"	3.2" - 4.5"	5	3
CPC5/6	ETPB*	5" - 6"	5.63" - 6.63"	5	9
APC5/6	Aluminum	5" - 6"	5.63" - 6.63"	5	5

- Feature "quick connect", bi-directional design.
- Pressed stud design ensures a flush mounting surface.

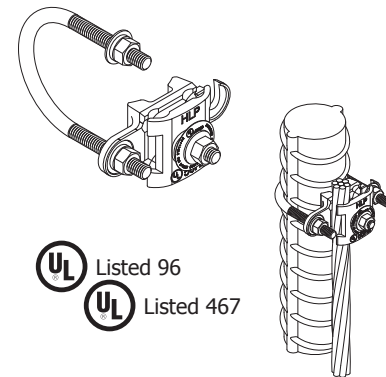

UL Listed 96
UL Listed 467

NOTES:

- Wide conductor range; #6 Solid through 250 MCM.
- CPC series only Dual UL Listing (UL96 and UL467).
- CPC series only acceptable for direct burial.

* Electro Tin Plated Bronze includes stainless steel hardware.

Ground Bar Hole Patterns

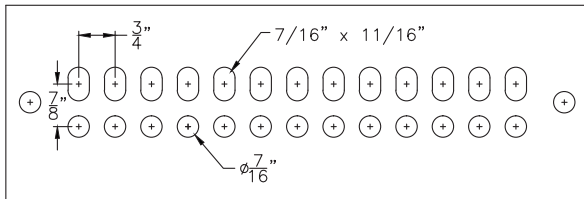

" P "

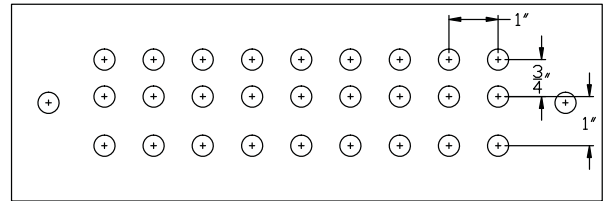

" J "

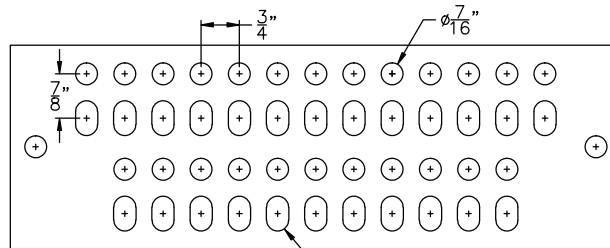

" M "

NOTES:

- All holes are 7/16" unless specified differently. To order threaded holes, specify hole size.
- The standard tapped hole size is 1/4-20 unless specified differently.
- Above bar patterns represent a 12" ground bar.
- All bars are available with electro-tin plating. Add prefix T to part number.
- For other hole patterns, please contact the factory.

GBI Ground Bars

"P" Pattern

Part No.	Bar Size	Hole Pattern	No. of Holes	Approx. Wt. (lbs.)
GBI14212P	1/4" x 2" x 6"	P	10	3
GBI14216P	1/4" x 2" x 12"	P	26	4
GBI1426P	1/4" x 2" x 16"	P	34	2

- Accommodates "B" and "C" spaced two hole lugs (3/4" and 1" on center).
- 12" bar pictured. Holes are 7/16" diameter and slots are 7/16" x 11/16".
- Manufactured from electrolytic tough pitch copper alloy 110.
- Bars available electro-tin plated. When ordering, add prefix "T" to part number.
- Other sizes available. Please contact factory for more information.

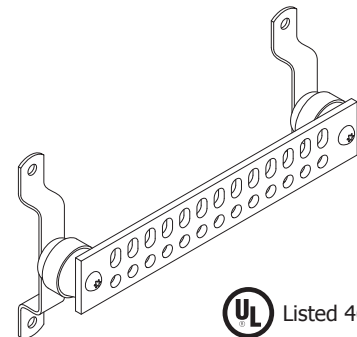

GBI Ground Bars

"J" Pattern

Part No.	Bar Size	Hole Pattern	No. of Holes	Approx. Wt. (lbs.)
GBI1446J	1/4" x 4" x 6"	J	9	4
GBI14412J	1/4" x 4" x 12"	J	27	5
GBI14416J	1/4" x 4" x 16"	J	39	7
GBI14420J	1/4" x 4" x 12"	J	51	7
GBI14424J	1/4" x 4" x 16"	J	63	8

- Mounting holes not included in total No. of Holes.
- Accommodates "B", "C" and "D" spaced two hole lugs (3/4", 1" and 1-3/4" on center).
- 12" bar pictured. Holes are 7/16" diameter.
- Manufactured from electrolytic tough pitch copper alloy 110.
- Bars available electro-tin plated. When ordering, add prefix T to part number.
- Other sizes available. Please contact factory for more information.

OPTIONAL

- Plexiglass cover with MGB lettering. Other lettering available.
- Cover manufactured from 1/4" plexiglass unless otherwise specified.
- Lettering must be 3/8" tall or larger.

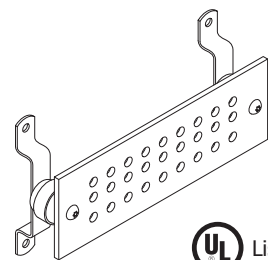

Listed 467

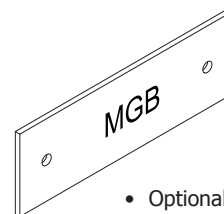

- Optional Cover. Add MGB suffix to part number.

"M" Pattern

Part No.	Bar Size	Hole Pattern	No. of Holes	Approx. Wt. (lbs.)
GBI1446M	1/4" x 4" x 6"	M	24	4
GBI14412M	1/4" x 4" x 12"	M	48	4
GBI14416M	1/4" x 4" x 16"	M	70	7
GBI14420M	1/4" x 4" x 12"	M	88	8
GBI14424M	1/4" x 4" x 16"	M	106	7

- Mounting holes not included in total No. of Holes.
- Accommodates "B" and "C" spaced two hole lugs (3/4" and 1" on center).
- 12" bar pictured. Holes are 7/16" diameter and slots are 7/16" x 11/16".
- Manufactured from electrolytic tough pitch copper alloy 110.
- Bars available electro-tin plated. When ordering, add prefix T to part number.
- Other sizes available. Please contact factory for more information.

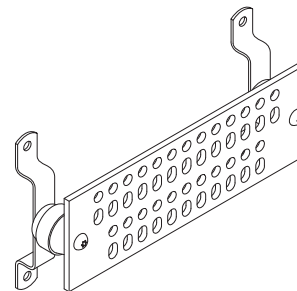

Listed 467

NOTES:

- All ground bars are available with factory exothermically welded tail.

Mounting Brackets

Wall Mount

Part No.	Mounting Hole Size	"H"	Heavy Duty	Box Qty.	Approx. Box Wt. (lbs.)
WBKT1	7/16"	1"	No	10	3
WBKT1KIT	7/16"	1"	No	5	5

- Manufactured from 304 series stainless steel or zinc plated steel.
- Special brackets available upon request.
- Kit includes two of the assembly (pictured) plus the 3/8" hardware required to mount to a ground bar.

Kit Includes:

- (2) WBKT1 □ stainless steel ground bar bracket
- (2) □4150 □4 □ ground insulator
- (2) □S66S □ 3/8"-16 x 3/4" stainless steel hex head cap screw
- (2) W6S □ 3/8" stainless steel flat washer
- (2) LW6S □ 3/8" stainless steel split lock washer

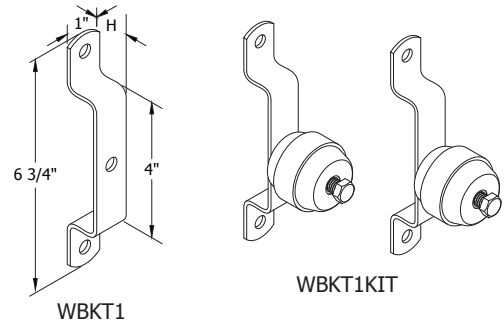

Stainless Steel Angle Adapters

Part No.	Qty.	Approx. Wt. (lbs.)
SS□□	10	5
SS□□KIT	5	8

- Manufactured from 304 series stainless steel.
- SS□□KIT includes two assemblies (pictured), 3/8" stainless steel hardware fastens kit to ground bar.
- SS□□KIT also includes □4150 □4 □ insulators.
- Will accommodate up to 1" thick material.

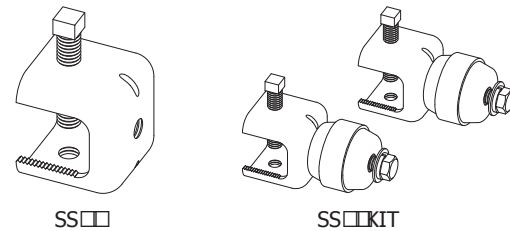

Insulated Tower Standoff for Round Members TSOINS Series

Insulated Tower Standoffs with Hose Clamp

Part No.	Hose Clamp included	Round Member Size OD	Box Qty.	Approx. Box Wt. (lbs.)
TS□□INS.75/1.75	Yes	.75" - 1.75"	10	6-1/4
TS□□INS2/2.75	Yes	2" - 2.75"	10	6-1/4
TS□□INS3/3.75	Yes	3" - 3.75"	10	6-1/4
TS□□INS4/4.75	Yes	4" - 4.75"	10	6-1/2
TS□□INS5/5.75	Yes	5" - 5.75"	10	6-1/2
TS□□INS6/6.75	Yes	6" - 6.75"	10	6-1/2

- The fast □ easy and economical way to make a quality isolated coaxial ground bar mount to round tower members.
- Manufactured from 300 series stainless steel for optimum compatibility.
- 3/8" x 1-1/2" insulator with 3/8-16 x 5/8" stainless steel hex head cap screw and lock washer included.
- Available with or without stainless steel hose clamps in a variety of sizes.
- Sold as 10 pack.

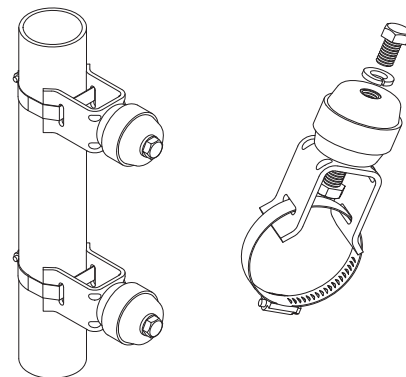

Copper Offset Terminal Lugs

Part No.	Conductor Range (AWG)		Bolt Hole Size	Ampere Rating	Box Qty.	Approx. Box Wt. (lbs.)
	Maximum	Minimum				
GEOL1	10 Stranded	14 Stranded	#8	25	100	2
GEOL2	6 Stranded	14 Stranded	#8	50	100	2
GEOL3	2 Stranded	8 Stranded	1/4"	70	100	4
GEOL4	1/0 Stranded	8 Stranded	1/4"	125	25	3
GEOL5	4/0 Stranded	2 Stranded	3/8"	225	25	6
GEOL500MCM	500 MCM	1/0 Stranded	1/2"	400	10	8

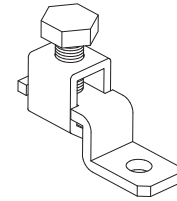

Listed 467

Copper Split Bolts

Part No.	Conductor Range for Equal Main (AWG)	Minimum Tap	Box Qty.	Approx. Box Wt. (lbs.)
GESB6	6 Sol. - 8 Sol.	16 SOL	100	6
GESB2	2 Str. - 6 Sol.	14 SOL	50	6
GESB1/0	1/0 Str. - 4 Sol.	14 SOL	20	4
GESB2/0	2/0 Str. - 2 Sol.	14 SOL	15	4
GESB4/0	4/0 Str. - 1/0 Sol.	10 SOL	10	4
GESB250	250 MCM - 1/0 Str.	10 SOL	10	4

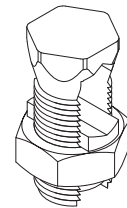

Listed 467

- Suitable for direct burial.

Ground Rod Clamps

Part No.	Ground Rod Size	Conductor Range (AWG)	Box Qty.	Approx. Box Wt. (lbs.)	UL Mark
300LD	1/2"	10 Sol. - #2 Str.	10	5	Yes
301LD	5/8"	10 Sol. - #2 Str.	10	1	Yes
302LD	3/4"	10 Sol. - #2 Str.	10	2	Yes
303LD	1"	8 Sol. - 4/0	10	6	Yes

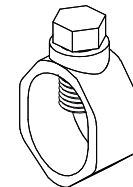

Listed 467

- Light duty ground rod clamp.
- Bronze cap screw secures the cable to the ground electrode.
- Commonly called acorn or tear drop clamp.

Universal Ground Rod Clamp - Light Duty

Part No.	Ground Rod Size	Conductor Range (AWG)	Box Qty.	Approx. Box Wt. (lbs.)	UL Mark
302UGRC	3/8"	1/0 - 10 SOL	10	2	No
	1/2"	1/0 - 10 SOL	10	2	Yes
	5/8"	1/0 - 10 SOL	10	2	Yes
	3/4"	1/0 - 8 SOL	10	2	Yes

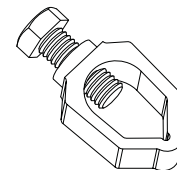

Listed 467

- Light duty ground rod clamp for securing cable to ground rod.
- Eliminates the need to inventory assorted different-size clamps.
- Replaces a wide range of products made for economy, standard duty, heavy duty and extra heavy duty applications.
- Made from corrosion resistant silicon bronze.
- Accommodates 3/8" to 3/4" ground rods and #10 Solid to 1/0 Stranded conductor.
- Tested to 300 inch-pounds.
- UL and CSA listed for Direct Burial.

NOTES:

Other sizes available. Please contact factory for more information.

Ultrafill - Earth (Ground) Enhancement Material

Ultrafill is a low resistance carbon based backfill material, which dramatically lowers ground system resistance in difficult soil situations. Ultrafill contains no bentonite or concrete components, which, in very dry conditions, can cause shrinkage around the ground electrode, thus rendering it ineffective.

Ultrafill is ideal for use in rocky soil, sand, gravel or any other high resistance soil conditions. It is also the ideal backfill material for use around enhanced ground rods and ground grid systems.

Ultrafill is easy to use, safe and effective. Unlike other backfill products, Ultrafill is relatively dust free and does not require mixing in water prior to installation.

Ultrafill may be either used in a horizontal trench or grid, or in vertical applications. Ultrafill is available in 25 and 50 pound coated woven polypropylene bags.

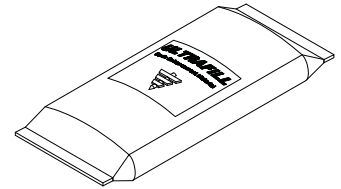

Part No.	Approx. Wt. (lbs.)
ULTRAFILL	50
ULTRAFILL25	25

Installation Instructions

Vertical Applications:

Auger hole to required depth. Insert electrode in center of hole. Pour Ultrafill to proper depth. The chart located to the right will help determine how much Ultrafill will be required.

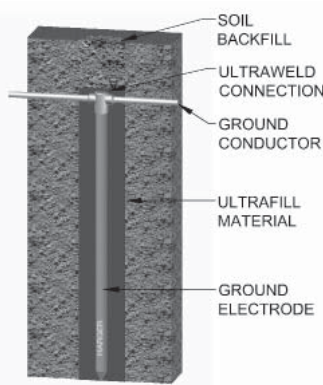

Pounds of Ultrafill Required Per Foot		
Hole Size	5/8" Ground Rod	2" EGR
4"	3.5	2.7
6"	8.1	7.3
8"	14.5	13.6
10"	22.6	21.8
12"	32.6	31.8

For example, placing a 5/8" x 10' ground rod in a 4" hole would require 35 pounds of Ultrafill. (3.5 x 10 = 35 pounds)

Horizontal Applications:

Pour enough Ultrafill to cover bottom of trench. Place the ground electrode into trench. Pour in additional Ultrafill to cover electrode to the desired depth.

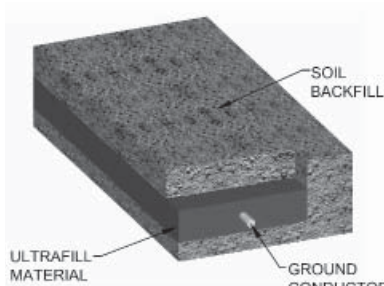

Pounds of Ultrafill Required Per Foot				
Trench Width	Thickness of Ultrafill (Inches)			
	1"	2"	3"	4"
4"	1.2	2.3	3.5	4.6
6"	1.7	3.5	5.2	6.9
8"	2.3	4.6	6.9	9.3
10"	2.5	5.8	8.7	11.6
12"	3.5	6.9	10.4	13.9

For example, using 2" of material in a 6" wide by 10' long trench would require 35 pounds of Ultrafill. (3.5 x 10 = 35 pounds)

Liquid Mixing Instructions:

To mix Ultrafill into a slurry for pumping applications, use the following formula:

- 6 parts water
- 1 part bentonite
- 1 part Ultrafill

Ground Access Wells

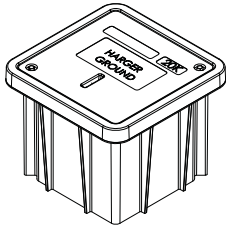

GAW121212HD

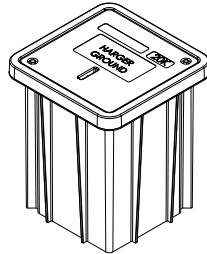

GAW121218HD

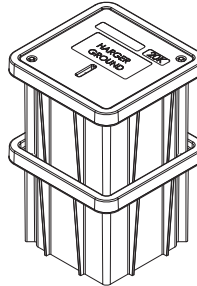

GAW121224HD*



GAW132418HD

Light Weight Polymer Concrete

Part No.	Dimensions	Approx. Wt. (lbs.)
GAW121212HD	12" x 12" x 12" deep	28
GAW121218HD	12" x 12" x 18" deep	33
GAW121224HD	12" x 12" x 24" deep	43
GAW132418HD	13" x 24" x 18" deep	78

- Lid & Grade Ring manufactured from 20,000 PSI high density polymer concrete.
- Body manufactured from sheet molding compound for exceptional toughness and reduced weight.
- Comes with 20,000# rated covers.
- Suitable for installation and use through a temperature range of -40°C to +90°C.
- Gray color.

* GAW121224HD is a two piece stackable, each 12" high.

ASTM C-857 Specifications

Cover Type	Cover Ratings	Live Load	30% Safety	Test Load	Test Area
Heavy Duty	10 Ton GVW (20,000#)	8,000#	10,400#	22,568#	10" x 10"

20,000# boxes and covers may be placed in locations that may see occasional non-deliberate heavy vehicles.

Covers exceed their rating by at least 20% and exceed ASTM test loads. No polymer concrete box or cover should be placed in a full traffic, H-20, application. Meets W.U.C. 3.6.

- GVW = Gross Vehicle Weight

Ground Access Wells

PVC Well with Cover

Part No.	Diameter	Length	Cover Type	Approx. Wt. (lbs.)
358PP	8"	24"	Plastic	12
358PS	8"	24"	Flat Steel	16
360PP	10"	24"	Plastic	21
360PS	10"	24"	Flat Steel	20
362PS	12"	24"	Flat Steel	27

- Schedule 40 PVC well.
- Steel covers are 3/16" thick commercial grade steel with a zinc/ultraseal coating.
- Plastic covers are manufactured from High Density Polyethylene.



HDPE Well with Cover

Part No.	Diameter	Length	Cover Type	Approx. Wt. (lbs.)
GAW910	9"	10-1/4"	HDPE	5

- Molded High Density Polyethylene well features a 9" diameter "twist lock" cover with locking bolt.
- Static vertical load rating = 350 PSF.
- 2 knock outs (mouse holes) allow for routing conductor to the inside.
- For use in non-vehicular traffic areas.



PVC Slotted Well with Cover

Part No.	Diameter	Length	Cover Type	Approx. Wt. (lbs.)
358P42	8"	42"	Flat Steel	23
358PP42	8"	42"	Plastic	21
360P42	10"	42"	Flat Steel	33
360PP42	10"	42"	Plastic	28

- Schedule 40 PVC well.
- Steel covers are 3/16" thick commercial grade steel with a zinc/ultraseal coating.
- Plastic covers are manufactured from High Density Polyethylene.
- Four 27" slots allow for ground electrode connections to be made before installation of test well.

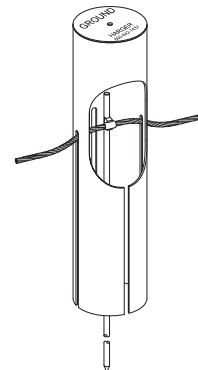

APPLICATION NOTES:

- Provides ready access to ground electrode for testing and inspection purposes.
- To prevent displacement by frost, the access well must be longer than the frost line is deep.

UL Listed Prefabricated Copper Ground Mesh

Harger prefabricated wire mesh can be supplied with no overhang, overlapping ends or butt splice ends.

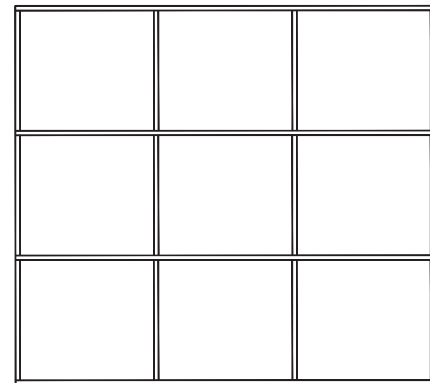

No Overhang

The overlapping end configuration is designed to allow for side by side connections of adjoining mats. This type of connection provides the easiest method of joining two mesh sections. Adding 2" to one half the conductor spacing provides the overlapping ends. For example, if the mesh size is 6" square, the overlapping end length is 5". See Page 25 for PS mold connection.

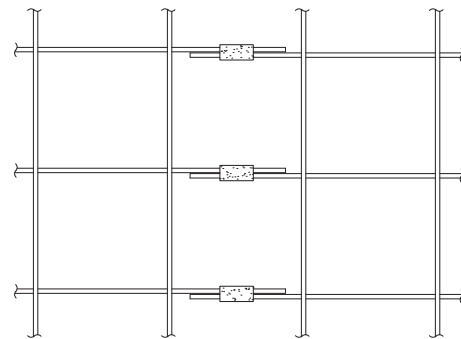

"Overlapping" ends

NOTES:

To connect mesh to ground, use PS connection type. See Page 25.

Mesh Net Weight in Pounds per Square Foot

Wire Type	Mesh Cell Size						
	4" x 4"	6" x 6"	8" x 8"	12" x 12"	24" x 24"	24" x 48"	48" x 48"
#10 Cu	0.199	0.132	0.099	0.067	0.034	0.027	0.019
8CW3D	0.257	0.171	0.129	0.087	0.045	0.035	0.024
#8 Cu	0.312	0.208	0.157	0.106	0.055	0.042	0.030
6CW3D	0.451	0.301	0.227	0.153	0.080	0.061	0.043
#6 Cu	0.491	0.328	0.248	0.167	0.087	0.067	0.047
#4 Cu	0.775	0.519	0.392	0.265	0.138	0.106	0.075

You need to first do the calculation for the net weight in order to calculate the gross shipping weight.

To Calculate Net Weight: Net Weight = Width (ft.) x Length (ft.) x Table Value (lb/ft²)

To Calculate Gross Shipping Weight: Gross Weight = Net Weight + [3.38 x (Mesh Width (ft.) + 1 (ft.))]

Example: 10' width x 65' length, #6 Cu Wire Type, 6" x 6" Cell Size (0.328 lb/ft²) per table above.
 Net Weight = 10 x 65 x 0.328 = 213 lbs.
 Gross Weight = 213 + [3.38 x (10 + 1)] = 250 lbs.

Personnel Safety Mats

Harger personnel safety mats are designed to protect against "touch potentials" under fault conditions. Listed below are standard mat configurations, however mats can be customized by utilizing the personnel safety mat numbering system. The following example is a safety mat that is 6' wide x 6' long made up of #6 solid copper conductor. Conductors are spaced every 12" and the mat has a 1/0 AWG solid center wire.

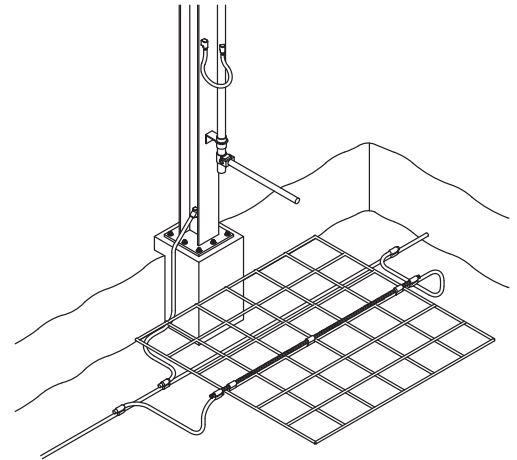
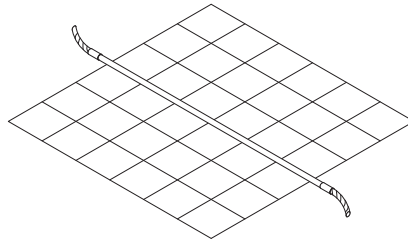

Personnel Safety Mat Numbering System

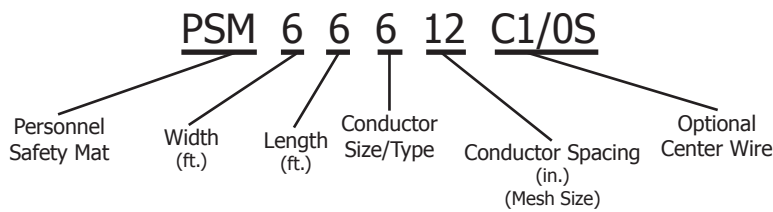

Standard Mat Configurations

- Mat Size: 4' x 4', 4' x 6', 6' x 6', 6' x 8'
- Wire Size: #4, #6, #8 AWG Solid Conductor
- Wire Type: Pure copper or copper clad steel (30% conductivity)
- Mesh Size: 2" square through 12" square in 2" increments
- Center Wire: Optional - See Page 63 for conductors available. Comes with standard 6" overhang on both sides of mat.

Conductors

Part No.	Type
4	Solid Copper
6	Solid Copper
6CW3D	Copper Clad 30% Conductivity
8	Solid Copper
8CW3D	Copper Clad 30% Conductivity

Standard Mat Sizes

Part No.	Width (ft.)	Length (ft.)	Conductor Size/Type (AWG)	Conductor Spacing (in.)	Optional Center Wire	Approx. Each Wt. (lbs.)
PSM4666C1/0S	4	6	6	6	1/0 Sol.	11
PSM4644C2/0	4	6	4	4	2/0	23
PSM61066C4/0S	6	10	6	6	4/0 Sol.	26

NOTES:

- 40% DSA conductor available. Please contact factory for more information.
- To connect mat to ground, use PT connection type. See page 26.
- Maximum mat width is 20 ft.

Part Number Index

Part Number	Page No.	Part Number	Page No.	Part Number	Page No.
1/0-19	46	ADPSLV1	39	CSKITHSVM	42
1/019G	46	ADPSLV1/0	39	CT2/02/0	54
2	47	ADPSLV2/0	39	CT4/02/0	54
2/0-7	46	ADPSLV2A	39	CT4/04/0	54
2/0-19	46	ADPSLV2B	39	CT22/0	54
2-7	46	ADPSLV3/0	39	CT24/0	54
2-19G	46	ADPSLV4	39	CT2222	54
2/019G	46	ADPSLV4/0	39	CT2248	54
2T	47	ADPSLV6	39	CT4446	54
3/16CBWB	16	APC1/1.25	56	CT4666	54
4	47	APC1.5/2	56	DAK	38
4-7	46	APC2.5/3	56	DISK15/65	41
4-19G	46	APC3.5/4	56	DISK90/115	41
4T	47	APC5/6	56	DISK150/500	41
5/16CBWB	16	ASCACGS6SX36	24	DISKKIT1	41
6	47	ASCACGS6SX48	24	DRONE	38
6-7	46	ASCACGS6SX60	24	DRONECASE	38
6-19G	46	ASCACGS6SX72	24	DRONECORD	38
6T	47	ASCF572	24	DRONEPOUCH	38
8	47	BS1/0B	25	FLTIG	39
8-7	46	BS1L	25	FLTIGEXT	39
8T	47	BS1MMC	25	G1134F1/ONU	29
10	47	BS2/0B	25	G1134F2/ONU	29
27G	46	BS2L	25	G1134F2NU	29
47G	46	BS3/0B	25	G1134F4/ONU	29
67G	46	BS3CMB	25	G1134F4NU	29
110	48	BS4/0B	25	G1134F8NU	29
126G	48	BS4L	25	G1158F1/ONU	29
126GUPC	48	BS5CMB	25	G1158F2/ONU	29
128G	48	BS6L	25	G1158F2NU	29
128GUPC	48	BS6SL	25	G1158F4/ONU	29
300LD	60	BS25CMB	25	G1158F4NU	29
301LD	60	BS35CMB	25	G1158F8NU	29
302LD	60	BS75CMC	25	G2134F1/ONU	29
302UGRC	60	BSLV3/16X1	16	G2134F2/ONU	29
303LD	60	BSLV3/16X1.5	16	G2134F2NU	29
348	48	BSLV3/16X.75	16	G2134F4/ONU	29
348G	48	BSLV5/16X1	16	G2134F4NU	29
358P42	63	CCBRSH1	40	G2134F8NU	29
358PP	63	CCBRSH2	40	G2158F2NU	29
358PP42	63	CCBRSH2R	40	G2158F4NU	29
358PS	63	CERPM1	40	G2158F8NU	29
360P42	63	CERPM2	40	G3134F1/ONU*	29
360PP	63	CERPM3	40	G3134F2NU	29
360PP42	63	CGS	40	G3134F4NU	29
360PS	63	CLBB2S	54	G3134F8NU	29
362PS	63	CLBBS2	54	G3158F1/ONU	29
588	48	CLBBS2/0	54	G3158F1/ONU*	29
588G	48	CLBBS4	54	G3158F2/ONU	29
588GUPC	48	CLBBS4/0	54	G3158F2NU	29
588RUS	48	CLBBS6	54	G3158F4/ONU	29
588SS3	48	CLBBS8	54	G3158F4NU	29
588UPC	48	CLBBS250	54	G3158F8NU	29
1208UPC	48	CLBBS500	54	G4134F2NU	29
1210	48	CPC1/1.25	56	G4134F4NU	29
1210SS3	48	CPC1.5/2	56	G4134F8NU	29
3410	48	CPC2.5/3	56	G4158F2NU	29
3410G	48	CPC3.5/4	56	G4158F4NU	29
3410SS3	48	CPC5/6	56	G4158F8NU	29
3412	48	CPC.5/.75	56	G11341/ONU	29
5810	48	CSH1	42	G11342/ONU	29
5810G	48	CSH2	42	G11342NU	29
5810GUPC	48	CSKIT	42	G11344/ONU	29
5810SS3	48	CSKITHP	42	G11344NU	29
5810UPC	48	CSKITHPVS	42	G11348NU	29

<u>Part Number</u>	<u>Page No.</u>	<u>Part Number</u>	<u>Page No.</u>	<u>Part Number</u>	<u>Page No.</u>
G11581/ONU	29	GD584L	27	GECLB500	52
G11582/ONU	29	GD586L	27	GECLB2502C	53
G11582NU	29	GD1025CMB	27	GECLB2502D	53
G11584/ONU	29	GD3425CMB	27	GECLB5002C	53
G11584NU	29	GD5825CMB	27	GECLB5002D	53
G11588NU	29	GDS1	49	GECLB7502C	53
G21341/ONU	29	GDS12	49	GECLB7502D	53
G21342/ONU	29	GDS34	49	GEOL1	60
G21342NU	29	GDS58	49	GEOL2	60
G21344/ONU	29	GECL1/0	52	GEOL3	60
G21344NU	29	GECL2	52	GEOL4	60
G21348NU	29	GECL2/0	52	GEOL5	60
G21581/ONU	29	GECL4	52	GEOL500MCM	60
G21582/ONU	29	GECL4/0	52	GESB1/0	60
G21582NU	29	GECL6	52	GESB2	60
G21584/ONU	29	GECL21/4	52	GESB2/0	60
G21584NU	29	GECL23/8	52	GESB4/0	60
G21588NU	29	GECL43/8	52	GESB6	60
G31341/ONU	29	GECL63/8	52	GESB250	60
G31342NU	29	GECL250	52	GJX2/024	50
G31344NU	29	GECL500	52	GJX2S24	50
G31348NU	29	GECLB1/0	52	GJX4/024	50
G31581/ONU	29	GECLB1/02C	53	GO102/0B	27
G31582NU	29	GECLB1/02D	53	GO104/0B	27
G31584NU	29	GECLB2	52	GO122/0B	27
G31588NU	29	GECLB2/0	52	GO122B	27
G41342NU	29	GECLB2/02C	53	GO124/0B	27
G41344NU	29	GECLB2/02D	53	GO124L	27
G41348NU	29	GECLB3/02C	53	GO126L	27
G41582NU	29	GECLB4	52	GO341/0B	27
G41584NU	29	GECLB4/0	52	GO342/0B	27
G41588NU	29	GECLB4/02C	53	GO342B	27
GAW910	63	GECLB4/02D	53	GO342SB	27
GAW121212HD	62	GECLB6	52	GO344/0B	27
GAW121218HD	62	GECLB6NP	52	GO344M	27
GAW121224HD	62	GECLB8NP	52	GO346L	27
GAW132418HD	62	GECLB21/4	52	GO581/0B	27
GBI1426P	57	GECLB21/4NP	52	GO582/0B	27
GBI1446J	58	GECLB22A	53	GO582B	27
GBI1446M	58	GECLB22B	53	GO582SB	27
GBI14212P	57	GECLB22BC	54	GO584/0B	27
GBI14216P	57	GECLB22BC250BK	54	GO584L	27
GBI14412J	58	GECLB22BCS	54	GO586L	27
GBI14412M	58	GECLB22BCS250BK	54	GO1025CMB	27
GBI14416J	58	GECLB22BCSNP	54	GO3425CMB	27
GBI14416M	58	GECLB22BS	53	GO5825CMB	27
GBI14420J	58	GECLB22C	53	GRD34I	49
GBI14420M	58	GECLB22CNP	53	GRD58	49
GBI14424J	58	GECLB22CS	53	GRDS34	49
GBI14424M	58	GECLB22CSNP	53	GRDS58	49
GD102/0B	27	GECLB23/8	52	HB1/0B	30
GD104/0B	27	GECLB23/8NP	52	HB1MMC	30
GD122/0B	27	GECLB42A	53	HB2/0B	30
GD122B	27	GECLB42B	53	HB2B	30
GD124/0B	27	GECLB42C	53	HB2SB	30
GD124L	27	GECLB43/8	52	HB3/0B	30
GD126L	27	GECLB62A	53	HB3CMB	30
GD341/0B	27	GECLB62ANP	53	HB4/0B	30
GD342/0B	27	GECLB62B	53	HB5CMB	30
GD342B	27	GECLB62BC	54	HB6B	30
GD342SB	27	GECLB62BC250BK	54	HB25CMB	30
GD344/0B	27	GECLB62C	53	HB35CMB	30
GD344L	27	GECLB62CNP	53	HB75CMC	30
GD346L	27	GECLB63/8	52	HD1/0B	30
GD581/0B	27	GECLB63/8NP	52	HD1MMC	30
GD582/0B	27	GECLB82ANP	53	HD2/0B	30
GD582B	27	GECLB82CNP	53	HD2A	30
GD582SB	27	GECLB83/8NP	52	HD2SA	30
GD584/0B	27	GECLB250	52	HD3/0B	30

Part Number	Page No.	Part Number	Page No.	Part Number	Page No.
HD3CMB	30	MIL1812CHARGER	38	PT4/02/0B	26
HD4/0B	30	MIL1840BAT	38	PT4/02B	26
HD4A	30	MLDSL	40	PT4/03/0B	26
HD5CMB	30	MLDSTBLZR	43	PT4/04/0B	26
HD6A	30	MSHC1	42	PT4/04B	26
HD6SA	30	MSHC2	42	PT4/06B	26
HD25CMB	30	MSKIT	42	PT4/06SB	26
HD35CMB	30	MSKITHSVS	42	PT4/08B	26
HD75CMC	30	NUWTUBE25	27	PT4/08SB	26
HMDIE3/16	16	NUWTUBE32	27	PT6S6SB	26
HMDIE3/16	16	OXL141	35	PT22B	26
HMDIE3/16	16	OXL141.5	35	PT24B	26
HMDIE5/16	16	OXL141.52B	35	PT26B	26
JXL-181	34	OXL141.52C	35	PT26SB	26
JXL-1812C1/4	34	OXL141.52D	35	PT28B	26
JXL-1812C3/8	34	OXL181	35	PT28SB	26
JXL-1812D	34	OXL381.5	35	PT44B	26
JXL-1813/8	34	OXL381.52B	35	PT46B	26
JXL-3161	34	OXL381.52C	35	PT46SB	26
JXL-31612D	34	OXL381.52D	35	PT48B	26
LBJ1/0181B	34	OXL382	35	PT48SB	26
LBJ2/0181B	34	OXL1412B	35	PT66B	26
LBJ2/03161B	34	OXL1412C	35	RASP	40
LBJ2S181B	34	OXL1412D	35	RBLTS1-3/16KTNT"L"	15
LBJ3/0181B	34	OXL1422B	35	RBLTS1-3/16KTUS"L"	15
LBJ3/03161B	34	OXL1422C	35	RBLTS1-3/16"L"	15
LBJ4/0181B	34	OXL1422D	35	RBLTS1.5-3/16KTNT"L"	15
LBJ4/03161B	34	OXL1812B	35	RBLTS1.5-3/16KTUS"L"	15
LBJ2181B	34	OXL1812C	35	RBLTS1.5-3/16"L"	15
LBJ4181B	34	OXL1812C3/8	35	RBLTS1-5/16KTNT"L"	15
LBJ6181B	34	OXL1812D	35	RBLTS1-5/16KTUS"L"	15
LE1MM122C	34	OXL3161	35	RBLTS1-5/16"L"	15
LE1MM382C	34	OXL3822B	35	RBLTS.75-3/16KTNT"L"	15
LE2/0141B	34	OXL3822C	35	RBLTS.75-3/16KTUS"L"	15
LE2/0141B	50	OXL3822D	35	RBLTS.75-3/16"L"	15
LE2/0141B	51	OXL31612B	35	RBLXS3/16KTNT"L"	15
LE2/0181B	34	OXL31612C	35	RBLXS3/16KTUS"L"	15
LE2S141B	34	OXL31612C3/8	35	RBLXS3/16"L"	15
LE2S141B	50	OXL31612D	35	RBJHC2/09	17
LE2S141B	51	PB2S2SB	25	RBJHC2/09KTNT	17
LE3CM141.5B	34	PB6S6SB	25	RBJHC2/09KTUS	17
LE3CM141B	34	PB22B	25	RBJHC2/013	17
LE4/0141.5B	34	PB24B	25	RBJHC2/013KTNT	17
LE4/0141B	34	PB26B	25	RBJHC2/013KTUS	17
LE4/0141B	50	PB26SB	25	RBJHC4/09	17
LE4/0141B	51	PB28SB	25	RBJHC4/09KTNT	17
LE4/03161B	34	PB44B	25	RBJHC4/09KTUS	17
LE5CM141.5B	34	PB46B	25	RBJHC4/013	17
LE5CM142B	34	PB46SB	25	RBJHC4/013KTNT	17
LE5CM381.5B	34	PB48SB	25	RBJHC4/013KTUS	17
LE5CM382C	34	PS6S6SL	25	RBJHC25013	17
LE25CM141.5B	34	PS8S8SL	25	RBJHC25013KTNT	17
LE25CM141B	34	PS66L	25	RBJHC25013KTUS	17
LE75CM142C	34	PS88L	25	RBJPTS1-3/16KTNT"L"	15
LE75CM381.5C	34	PSM4644C2/0	65	RBJPTS1-3/16KTUS"L"	15
LE75CM382C	34	PSM4666C1/0S	65	RBJPTS1-3/16"L"	15
LE2181B	34	PSM61066C4/0S	65	RBJPTS1.5-3/16KTNT"L"	15
LE4181B	34	PT2/01/0B	26	RBJPTS1.5-3/16KTUS"L"	15
LE6181B	34	PT2/01B	26	RBJPTS1.5-3/16"L"	15
MCBRSH1	41	PT2/02/0B	26	RBJPTS1-5/16KTNT"L"	15
MCBRSH2	41	PT2/02B	26	RBJPTS1-5/16KTUS"L"	15
MCSPPD25/115	41	PT2/04B	26	RBJPTS1-5/16"L"	15
MCSPPD150/400	41	PT2/06B	26	RBJPTS.75-3/16KTNT"L"	15
MCT	55	PT2/06SB	26	RBJPTS.75-3/16KTUS"L"	15
MCT81/0	14	PT2/08B	26	RBJPTS.75-3/16"L"	15
MCT81/0	55	PT2/08SB	26	RBJPXS3/16KTNT"L"	15
MH1	42	PT2S2SB	26	RBJPXS3/16KTUS"L"	15
MH2	42	PT4/01/0B	26	RBJPXS3/16"L"	15
MH3	42	PT4/01B	26	RBSWTS1-3/16KTNT"L"	15

Part Number	Page No.	Part Number	Page No.	Part Number	Page No.
RBSWTS1-3/16KTUS"L"	15	RMJHC25013T8FRM	17	RT2/04B	26
RBSWTS1-3/16"L"	15	RMVH1/0WEBK	20	RT2S2SB	26
RBSWTS1.5-3/16KTNT"L"	15	RMVH1WEBK	20	RT3/01/0B	26
RBSWTS1.5-3/16KTUS"L"	15	RMVH2/0WEBK	20	RT3/02/0B	26
RBSWTS1.5-3/16"L"	15	RMVH2WEBK	20	RT3/02B	26
RBSWTS1-5/16KTNT"L"	15	RMVH4/0WEBK	20	RT3/03/0B	26
RBSWTS1-5/16KTUS"L"	15	RMVH4WEBK	20	RT3/04B	26
RBSWTS1-5/16"L"	15	RMVL1/0WEBK	21	RT4/01/0B	26
RBSWTS.75-3/16KTNT"L"	15	RMVL1WEBK	21	RT4/01B	26
RBSWTS.75-3/16KTUS"L"	15	RMVL2/0WEBK	21	RT4/02/0B	26
RBSWTS.75-3/16"L"	15	RMVL2WEBK	21	RT4/02B	26
RBSWXS3/16KTNT"L"	15	RMVL4/0WEBK	21	RT4/03/0B	26
RBSWXS3/16KTUS"L"	15	RMVL4WEBK	21	RT4/04/0B	26
RBSWXS3/16"L"	15	RMVR1/0WEBK	21	RT4/04B	26
RBTC3/164	14	RMVR1WEBK	21	RT6S6SB	26
RBTC3/164KTNT	14	RMVR2/0WEBK	21	RT22B	26
RBTC3/164KTUS	14	RMVR2WEBK	21	RT24B	26
RBTC3/1612	14	RMVR4/0WEBK	21	RT44B	26
RBTC3/1612KTNT	14	RMVR4WEBK	21	RT66B	26
RBTC3/1612KTUS	14	RMWT21FRM	14	SAFHB25115	37
RBWJC1/0B"L"	19	RMWTS1-3/16T21	14	SAFHB150300	37
RBWJC1/0INS"L"	19	RMWTS1-3/16T21	15	SAFHC400	37
RBWJC1/0RB"L"	19	RMWTS1-3/16T21	15	SMGRD58U	49
RBWJC1/0RINS"L"	19	RMWTS1-3/16T21	15	SMGRD58USHGR	49
RBWJC2/0B"L"	19	RMWTS1-3/16T21	16	SSAA	59
RBWJC2/0INS"L"	19	RMWTS1-3/16X	14	SSAAKIT	59
RBWJC2/0RB"L"	19	RMWTS1-3/16X	15	SSCGP6SX36	24
RBWJC2/0RINS"L"	19	RMWTS1-3/16X	15	SSCGP6SX36SS	24
RBWJC4/0B"L"	19	RMWTS1-3/16X	15	SSCGP6SX48	24
RBWJC4/0INS"L"	19	RMWTS1-3/16X	16	SSCGP6SX48SS	24
RBWJC4/0RB"L"	19	RMWTS1.5-3/16T21	15	SSCGP6SX60	24
RBWJC4/0RINS"L"	19	RMWTS1.5-3/16T21	15	SSCGP6SX60SS	24
RBWJC250RB"L"	19	RMWTS1.5-3/16T21	15	SSCGP6SX72	24
RBWJC250RINS"L"	19	RMWTS1.5-3/16T21	16	SSCGP6SX72SS	24
RBWJC300RB"L"	19	RMWTS1.5-3/16X	15	SXL141	35
RBWJC300RINS"L"	19	RMWTS1.5-3/16X	15	SXL141.5	35
RBWJC350RB"L"	19	RMWTS1.5-3/16X	15	SXL141.52B	35
RBWJC350RINS"L"	19	RMWTS1.5-3/16X	16	SXL141.52C	35
RBWJC500RB"L"	19	RMWTS1-5/16T21	15	SXL141.52D	35
RBWJC500RINS"L"	19	RMWTS1-5/16T21	15	SXL181	35
RMJHC2/0T9	17	RMWTS1-5/16T21	15	SXL381.5	35
RMJHC2/0T9	17	RMWTS1-5/16T21	16	SXL381.52B	35
RMJHC2/0T9FRM	17	RMWTS1-5/16X	15	SXL381.52C	35
RMJHC2/0T9FRM	17	RMWTS1-5/16X	15	SXL381.52D	35
RMJHC2/0X	17	RMWTS1-5/16X	15	SXL382	35
RMJHC2/0X	17	RMWTS1-5/16X	16	SXL1412B	35
RMJHC2/0X	17	RMWTS.75-3/16T21	15	SXL1412C	35
RMJHC2/0X	17	RMWTS.75-3/16T21	15	SXL1412D	35
RMJHC2/09T8	17	RMWTS.75-3/16T21	15	SXL1422B	35
RMJHC2/09T8FRM	17	RMWTS.75-3/16T21	16	SXL1422C	35
RMJHC2/013T8	17	RMWTS.75-3/16X	15	SXL1422D	35
RMJHC2/013T8FRM	17	RMWTS.75-3/16X	15	SXL1812B	35
RMJHC4/0T9	17	RMWTS.75-3/16X	15	SXL1812C	35
RMJHC4/0T9	17	RMWTS.75-3/16X	16	SXL1812C3/8	35
RMJHC4/0T9FRM	17	RMWXS3/16T21	15	SXL1812D	35
RMJHC4/0T9FRM	17	RMWXS3/16T21	15	SXL3161	35
RMJHC4/0X	17	RMWXS3/16T21	15	SXL3822B	35
RMJHC4/0X	17	RMWXS3/16X	15	SXL3822C	35
RMJHC4/0X	17	RMWXS3/16X	15	SXL3822D	35
RMJHC4/0X	17	RMWXS3/16X	15	SXL31612B	35
RMJHC4/09T8	17	RPLFLT	39	SXL31612C	35
RMJHC4/09T8FRM	17	RT1/01/0B	26	SXL31612C3/8	35
RMJHC4/013T8	17	RT1/01B	26	SXL31612D	35
RMJHC4/013T8FRM	17	RT1/02B	26	TRCHD	39
RMJHC250T9	17	RT1/04B	26	TSOCINS2/2.75	59
RMJHC250T9FRM	17	RT2/01/0B	26	TSOCINS3/3.75	59
RMJHC250X	17	RT2/01B	26	TSOCINS4/4.75	59
RMJHC250X	17	RT2/02/0B	26	TSOCINS5/5.75	59
RMJHC25013T8	17	RT2/02B	26	TSOCINS6/6.75	59

<u>Part Number</u>	<u>Page No.</u>	<u>Part Number</u>	<u>Page No.</u>
TSOCINS.75/1.75	59	VL4B	33
ULTRAFILL	61	VL5CMB	33
ULTRAFILL25	61	VL6B	33
ULTRAWRAP	41	VL25CMB	33
UMHDKIT	43	VL35CMB	33
UMMHDA	43	VR1/0B	33
UPC1.5/2	51	VR2/0B	33
UPC2.5/3	51	VR2B	33
UPC3.5/4	51	VR2SB	33
UPC5/6	51	VR3/0B	33
UPC.75/1.25	51	VR3CMB	33
US25	27	VR4/0B	33
US32	27	VR4B	33
USSKIT1	37	VR5CMB	33
USSKIT2	37	VR6B	33
USSKIT3	37	VR25CMB	33
USSXADPTR	37	VR35CMB	33
USSXFLR1.8	37	VT1/0K	32
USSXFLR2	37	VT2/0K	32
USSXFLR3	37	VT2B	32
VA1/0B	31	VT2SB	32
VA1MMC	31	VT3/0K	32
VA2/0B	31	VT4/0K	32
VA2B	31	VT4B	32
VA2SB	31	VT6B	32
VA3/0B	31	VT25CMK	32
VA3CMB	31	WBKT1	59
VA4/0B	31	WBKT1KIT	59
VA4B	31	WRPSLV	39
VA5CMB	31		
VA6B	31		
VA25CMB	31		
VA35CMB	31		
VA75CMC	31		
VD1/0B	31		
VD2/0B	31		
VD2/0V1.25X4B	31		
VD2B	31		
VD2SB	31		
VD2SV1.25X4B	31		
VD3/0B	31		
VD3CMB	31		
VD4/0B	31		
VD4/0V1.25X4B	31		
VD4B	31		
VD5CMK	31		
VD6B	31		
VD25CMB	31		
VD35CMB	31		
VDRFP2/0B	50		
VDRFP2SB	50		
VDRFP4/0B	50		
VH1/0B	32		
VH2/0B	32		
VH2B	32		
VH2SB	32		
VH3/0B	32		
VH4/0B	32		
VH4B	32		
VH5CMC	32		
VH6B	32		
VH25CMB	32		
VL1/0B	33		
VL2/0B	33		
VL2B	33		
VL2SB	33		
VL3/0B	33		
VL3CMB	33		
VL4/0B	33		

Key Word Index

6' Cord	38	PVC Well with Cover	63
Adapter Sleeves	39	Ground Bar Hole Patterns	57
Adapting Molds to Fit Conductors	39	Ground Rod Clamps.....	60
Battery	38	Ground Rod Driver	49
Bond Strand Signal Cable.....	16	Ground Rods.....	45
Cable Cleaning Brush.....	40	HDPE Well with Cover.....	63
Cable Cleaning Brush - Heavy Duty.....	41	Heavy Duty C-Taps	54
Cable & Work Surface Preparation	40	Hold Down Kit.....	43
Case.....	38	Insulated Tower Standoff for Round Members TSOINS Series.....	59
Ceramic Rebar Packing Material.....	40	Insulated Tower Standoffs with Hose Clamp	59
Chain Support Handle Clamp.....	42	Jumper, Bootleg & Switch Bonds (Web).....	15
Chain Support Kits.....	42	Long Barrel Butt Splices.....	54
Charger	38	Low Smoke-No Flame Adapter Clamp	37
Clamps.....	60	Low Smoke-No Flame Kits.....	37
Cold Galvanizing Spray	40	Low Smoke-No Flame System	37
Conductor Identification.....	44	Lugs	
Conductor Specifications (C-Type Bonds).....	22	One Hole, Long Barrel, Compression Lugs.....	52
Conductor Specifications for Copper Concentric Strand (W-Type Bonds)	22	One Hole, Standard Barrel, Compression Lugs....	52
Conductor Specifications for Copper Ropelay (W-Type Bonds)	22	Two Hole, Long Barrel, Compression Lugs.....	53
Connection Types	10	Two Hole, Slotted, Long Barrel, Compression Lugs	54
Copper Clad Steel Ground Rod	48	Magnetic Support Handle Clamp.....	42
Copper Offset Terminal Lugs	60	Magnetic Support Kit	42
Copper Split Bolts.....	60	Mechanical Compression Tools	14,55
CPC & APC Pipe Clamps.....	56	Mold Accessories.....	39
Pipe Range 1/1.25.....	56	Flint Igniter.....	39
Pipe Range 1.5/2 - 5/6	56	Torch Head	39
Pipe Range .5/.75.....	56	Mold Blanket.....	43
C-Type Compression Taps.....	54	Mold Care & Use	41
Drive Sleeves	49	Disk Kit.....	41,43
Drive Studs.....	49	Disks.....	41
Drone.....	38	Mold Cleaning Brushes.....	41
Drone Accessories	38	Mold Cleaning Spades.....	41
6' Cord	38	Mold Fastening & Mounting	42,43
Battery	38	Mold Handle Clamp	42
Case.....	38	Mold Sealer.....	40
Charger	38	Mold Stabilizer Kit.....	43
Pouch.....	38	Mounting Brackets.....	59
Exothermic Process	7	Stainless Steel Angle Adapters.....	59
Flexible Gate Jumpers.....	50	Wall Mount	59
LE Connection Type.....	50	NUWTube Pour & Shoot Process.....	9
Flint Igniter.....	39	NUWTube Uni-Shots	
Galvanized Steel Ground Rod	48	G11.....	29
GBI Ground Bars	57,58	G21.....	29
"J" Pattern	58	G31.....	29
"M" Pattern	58	G41.....	29
"P" Pattern.....	57	Personnel Safety Mats	65
Green Insulated Conductor	46	Pouch.....	38
Ground Access Wells	62	Propulsion Rail Head Bonds (C-Type)	17
HDPE Well with Cover.....	63	Propulsion Web Bonds (W-Type).....	18
Light Weight Polymer Concrete.....	62	Joint/Cross Bonds.....	19
PVC Slotted Well with Cover	63	Joint/Cross Bonds (Bare & Insulated).....	19
		Stub End Bonds (Bare & Insulated)	18

Key Word Index

PVC Slotted Well with Cover	63	PS.....	25
PVC Well with Cover	63	PT.....	26
Rasp	40	RT.....	26
Replacement Filter Housing.....	37	VA.....	31
Signal Bonds (Welded).....	12	VD	31
3/16" Joint Head Bonds, Welders & Molds.....	12	VH	32
3/16" Tab Style Bonds	12	VL.....	33
3/16" XS Style Bonds.....	12	VR.....	33
5/16" Joint Head Bonds, Welders & Molds.....	13	VT.....	32
5/16" Tab Style Bonds	13	Universal Ground Rod Clamp.....	60
Bond Strand Signal Cable.....	16	Universal Pipe Clamps.....	51
Field Made Tab Style Bonds.....	16	LE Connection Type.....	51
Jumper, Bootleg & Switch Bonds (Web).....	15	Web Grounding Connections	20
Signal Hut Grounding	24	RMVH.....	20
Aluminum to Copper Ground Studs.....	24	RMVL	21
Feedthrough Stud.....	24	RMVR.....	21
Steel Signal Case Ground Plates	24	Weld Metal	36
Single Rail Head Welders	13	Wrap Sleeves	39
Slotted Long Barrel Compression Lugs	54		
Solid Copper Conductor	47		
Solid Single Soft-Drawn Bare Copper	47		
Solid Tinned Copper Conductor	47		
Solid Single Soft-Drawn Bare Tinned Copper	47		
Stainless Steel Ground Rod	48		
Stranded Copper Conductor	46		
Concentric Lay Soft-Drawn Bare Copper	46		
Technical Information	44		
Copper-Clad Steel Conductors	45		
Ground Rods.....	45		
Tinned Copper Lugs - Bent J.....	34		
Tinned Copper Lugs - Straight & Offset.....	35		
Track Circuit Connectors (Web)	14		
1" x 3/16" Web Welder	14		
3/16" Diameter Track Connectors	14		
Two Hole Long Barrel Compression Lugs.....	53		
UL Listed Prefabricated Copper Ground Mesh	64		
Ultrafill - Earth (Ground) Enhancement Material.....	61		
UltraShot Drone	38		
UltraShot Drop-In Process.....	8		
Ultra Uni-Shots.....	28		
G11.....	28		
G21.....	28		
G31.....	28		
G41.....	28		
Ultraweld Connections			
BS.....	25		
GD	27		
GO	27		
HB	30		
HD	30		
LBJ.....	34		
LE	34		
PB.....	25		



ULTRAWELD®



Harger Lightning & Grounding
301 Ziegler Drive, Grayslake, IL 60030
800.842.7437 | 847.548.8700 | Fax: 847.548.8755
Email: hargersales@harger.com | Website: www.harger.com