

ULTRAWELD Installation Instructions

HCVSE Connection Type Horizontal Copper Vertical Stud End



PRECAUTIONS:

Follow General Safety & Preparation of Cable instructions on the backside of this sheet.

HCVSE

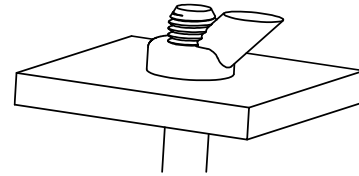

GENERAL WELDING PROCEDURE:

1. Check mold tag for conductors to be welded and proper weld metal cartridge size to use.
2. Make sure all surfaces and conductors are clean, dry and are the proper sizes for the mold's application per mold tag.
3. Molds can be dried by heating to approximately 250°F. Molds may be dried with a hand operated propane torch.
4. Position mold onto conductor(s). Lock mold with handle clamps or frame, whichever is the case.

5A. For UltraShot Drop-In process

- Insert UltraShot cartridge into mold.
- Close lid and attach Drone cord to UltraShot igniter.
- Before igniting, verify conductor positioning and that mold is closed completely.
- Push and hold both ignitor buttons at the same time until audible alert is heard

5B. For NUWtube Pour & Shoot process

- Insert steel disk being sure it is directly centered over the tap hole. Failure to insert disk into mold will create improper welds and spewing of weld metal.
- Pour cartridge or cartridges into the crucible being careful not to upset the steel disk. Tap bottom of cartridge to loosen all starting powder and spread 2/3 of the powder evenly over the top of the welding powder. Close the mold lid and pour the remaining starting powder into the ignition pocket on top of mold lid.
- Before igniting, verify conductor positioning and that mold is closed completely.
- Close cover and ignite starting powder with flint gun.
- Pull flint gun away quickly to prevent fouling flint. When necessary to hold down on mold cover use a long tool to keep hand away from flash of igniting powder.

6. Wait approximately 30 seconds before opening mold to permit metal to solidify.

HCVSE WELDING PROCEDURE:

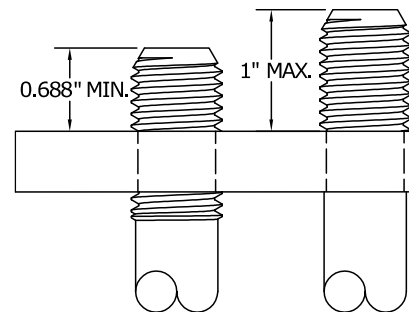

Ensure there is at least 0.688" of threaded rod exposed above the copper plate. Do not allow more than 1" of threaded rod to protrude.

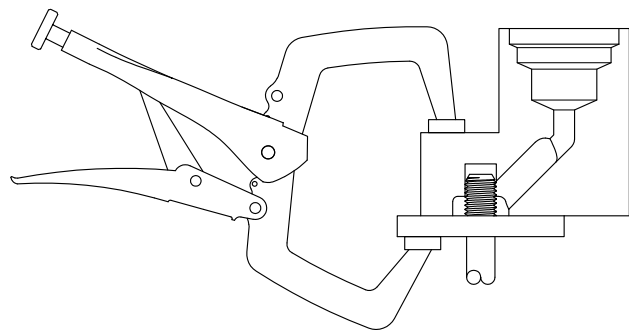

Thoroughly preheat copper plate and threaded rod, then place mold onto threaded rod and secure mold to copper plate using a clamp.

Note: A copper flat strap of 0.032" maximum thickness may be placed between the mold and copper plate when welding. A hole must be drilled or punched in the strap and then placed over the threaded rod and onto the plate prior to welding.

HARGER®

301 Ziegler Drive, Grayslake, IL 60030
Phone: 847-548-8700
Fax: 847-548-8755
Website: www.harger.com

ULTRAWELD Installation Instructions

HCVSE – Horizontal Copper Vertical Stud End Continued

GENERAL SAFETY INSTRUCTIONS:

1. Always wear proper clothing, safety glasses and gloves when exothermic welding.
2. Only weld items that the mold is designed for.
3. Do not use worn or broken molds which could cause leakage of molten weld metal.
4. Make sure that the conductors being welded fits in the mold properly and that the mold will close tightly around them.
5. Do not alter molds or accessories without factory authorization.
6. Avoid breathing concentrations of smoke, as it may be hazardous to your health.
7. Avoid contact with hot materials.
8. Remove or protect fire hazards in the welding area.
9. Avoid moisture and contaminants in the mold and conductors being welded. Contact of molten weld metal with moisture or contaminants may cause weld metal to spew out of mold.
10. Failure to abide by the above and follow welding procedures may result in improper welds, damage to the material being welded or create hazardous situations for the individual.

MOLD CARE:

- Do not use a wire brush to clean mold
- Do not use a screwdriver to clean the mold
- Clean mold with soft bristle mold cleaning brush to remove slag and residue
- Do not push conductor into a closed mold
- Store molds in a dry environment

PREPARATION OF GROUND RODS & STUDS:

1. The site of the weld on the ground rod or stud must be clean. Use a coarse file to remove rust and oxide before welding.

PREPARATION OF BUS BARS AND LUGS:

1. Bus bars and lugs must be bright, clean, and dry on all surfaces that are within the weld area in the mold.
2. Use a file or card cloth brush to remove oxides.